

COATS®

9010 A/E

Rim Clamp® Tire Changer

For servicing single piece automotive and most light truck tire/wheel assemblies



Parts Identification

READ these instructions before placing unit in service KEEP these and other materials delivered with the unit in a binder near the machine for ease of reference by supervisors and operators.

HENNESSY INDUSTRIES, INC.

HENNESSY INDUSTRIES INC. Manufacturer of AMMCO®, COATS® and BADA® Automotive Service Equipment and Tools.

Manual Part No.: 8183613 06
Revision: 10/00

Parts Identification

Ref No.	Description	Part No.	Description	Ref No.	Description	Part No.	Description
1	7908884 Chassis - Body	50	2108115 Locking Plate	99	4198671 Reduction 2530 1/4"-1/8"	108	8180560 Ground Cable
2	7910311 Side Cover	51	3007839 Locking Spring	100	4199818 Union 1/4"-Tee	109	4399946 Screw M 8 x 16 8.8
3	6605691 Pedal Divider Bracket	52	4299522 Lip Seal D. 60	101	6602899 18LT Tank D. 245	110	2009090 1PH Reverser Cable
4	4399364 Screw	53	4398762 Set Screw M 10 x 25	102	4398819 Screw M 10 x 20	111	8180638 Motor Capacitor Only
5	4398723 Screw M 6 x 12 8.8	54	4399976 Nut M 8	103	4399837 Screw M 8 x 20 10.9	112	4399900 Self-Locking Nut
6	3002099 Plastic Foot	55	4397527 Screw 8 x 30 10.9	104	3002289 Tank Support	113	4399863 Washer 8 x 24 x 2
7	7907791 Front Cover	56	6608895 GT Pressure Gauge Box D. 95	105	4198852 Union 3 Pcs. (125) 1" F/M 90°	114	3008333 Cylinder Liner R.H.
8	4399998 Washer M 6 (6,4 x 12 x 1,6)	57	4399135 Screw M 6 x 35 8.8	106	3005041 Hose 1" MM .190	115	3008902 Arm Front Protective Cover
9	4399998 Washer M 6 (6,4 x 12 x 1,6)	58	7906888 Bracket L.H.	107	6607546 Bead Helper Disk Arm	116	4399897 Screw M 4 x 25 8.8
10	8181354 Bead Lifting Tool	59	7908819 Left Helper Base	108	8180560 Ground Cable	117	4398274 Self-Tapping Screw 5.5 x 26
11	3002102 B.L. Pad	60	7908888 Arm	109	4399946 Screw M 8 x 16 8.8	118	4399038 Screw M 4 x 8
12	4398848 Washer M 6 (6,6 x 11 x 1,5)	61	2108818 Vertical Arm L.H.	110	2009090 1PH Reverser Cable	119	
13	4399999 Screw M 6 x 25 8.8	62	7908820 Cover L.H.	111	8180638 Motor Capacitor Only	120	3199599 Seeger Ring D-30
14	4399288 Toothed Washer 6,4 x 11 x 0,7	63	3006106 Locking Plate	112	4399900 Self-Locking Nut	121	4398723 Screw M 6 x 12 8.8
15	4398108 Self-Tapping Screw TCEI 6,3 x 16	64	3008889 Operating Arm L=855,5	113	4399863 Washer 8 x 24 x 2	122	2099665 Locking Cylinder
16	4399945 VIS M 16 x 100 8.8	65	3009044 Mounting Head Shock Absorber	114	3008333 Cylinder Liner R.H.	123	8111186 Pressure Limiter Assembly
17	4399963 Self Locking Nut M 16	66	2008968 Outer Cylinder Liner	115	3008902 Arm Front Protective Cover	124	8181100 Motor 1PH 115 Volt 60Hz
18	4398178 Seeger Ring D. 40E	67	4399134 Screw TCEI M 8 x 30 8.8	116	4399897 Screw M 4 x 25 8.8	125	3000114 Bead Loosener Spring
19	3008990 Swinging Pin D. 40	68	7907542 Arm I for L.H.	117	4398274 Self-Tapping Screw 5.5 x 26	126	3008886 ABS Cover
20	6608963 Grease Cup Ring	69	3010283 Metal Handgrip M 10 x 7	118	4399038 Screw M 4 x 8	127	4199671 Quick Relief Valve 1/4"
21	7908947 Bead Loosener Arm	70	3009088 Washer D. 10 x 45 x 4	119		128	4398327 Retaining Pin D.5 x 18
22	4397846 Nut M 14 Tribkok	71	7908982 Arm 2 L.H.	120	3199599 Seeger Ring D-30	129	2108715 20" Scalloped Turntable
23	4399812 Steel Spacer 25 x 35 x 1,5	72	2108983 Arm 3 L.H.	121	4398723 Screw M 6 x 12 8.8	130	2007414 18/19/20" Turntable Flange
24	4398899 Belleville Spring 14,3 x 34 x 1,5	73	3008404 Bead-Pressing Tool 50 x 90 x 170	122	2099665 Locking Cylinder	131	4199671 Quick Relief Valve 1/4"
25	3010293 Articulated Pin	74	4399228 Screw	123	8111186 Pressure Limiter Assembly	132	4399423 Screw M 10 x 70 8.8
26	2110308 Break Loosener Blade	75	3008793 Shock Absorber D. 21 x 32 x 10	124	8181100 Motor 1PH 115 Volt 60Hz	133	3002629 Spring 13.5 x 28F 2.3
27	4399933 Screw M 10 x 50 8.8	76	3006862 Disk Pin	125	3000114 Bead Loosener Spring	134	4298812 Sealing Ring 16 x 8 x 6
28	4398725 Locknut MA. 18 Din .982	77	4399966 Bead Helper Disk	126	3008886 ABS Cover	135	2008969 Inner Cylinder Liner 9010E
29	4299925 Transmission	78	4399966 Screw M 10 x 20 x 8.8	127	4199671 Quick Relief Valve 1/4"	136	3002273 Spring
30	3199596 Pulley	79	6607545 Arm 4 Press Arm 2	128	4398327 Retaining Pin D.5 x 18	137	3007640 Rectangular Plug
31	3199598 Hex Nut M 14	80	4199668 Reduction 2520 3/8"F-1/4"M	129	2108715 20" Scalloped Turntable	138	4399895 Self-Locking Nut M 4
32	4299923 V-Belt A 23	81	7908981 Slide L.H.	130	2007414 18/19/20" Turntable Flange	139	4399896 Screw TE 4 x 35 8.8
33	3007932 Cover B.L. Channel	82	7906887 Base Column L.H.	131	4199671 Quick Relief Valve 1/4"	140	4399300 Screw M 6 x 12 8.8
34	3199597 Washer D. 14	83	3008433 Roller D. 102 L=120	132	4399423 Screw M 10 x 70 8.8	141	4198808 Silencer 1/4"
35	8181204 Pulley 5/8" Shaft	84	2108962 Horizontal Arm R.H.	133	3002629 Spring 13.5 x 28F 2.3	142	4198894 Sleeve
36	8180217 5/16-18 x 3/8" SHCS Gr5	85	7907548 Slide R.H.	134	4298812 Sealing Ring 16 x 8 x 6	143	2004804 Cylinder Gasket Kit D. 75
37	3000149 Motor Mounting Bracket	86	2108815 Vertical Arm R.H.	135	2008969 Inner Cylinder Liner 9010E	144	4399865 Self-Locking Nut M12
38	8180558 Key-Motor Pulley	87	7908817 Cover R.H.	136	3002273 Spring	145	4398753 Washer D. 12.5 x 30 x 3
39	3009012 Spring Clip	88	6604693 Filter/Lubricator Bracket	137	3007640 Rectangular Plug	146	3006649 Cylinder Shaft R.H.
40	3009017 Cylinder Pin	89	4297851 Handle	138	4399895 Self-Locking Nut M 4	*	Indicates Accessory Item
41	8183710 Tire Lubricant 3.5 Kg Bucket	90	7906853 Cover R.H.-Top	139	4399896 Screw TE 4 x 35 8.8		
42	3199628 Tube Applicator	91	7908816 Right Helper Base	140	4399300 Screw M 6 x 12 8.8		
43	4399786 Screw M 10 x 30 8.8	92	4198883 Union 6500 1/4"-90°	141	4198808 Silencer 1/4"		
44	4399967 Nut M 10	93	8182827 Filter-Lubricator	142	4198894 Sleeve		
45	7908885 Vertical Arm	94	4198973 Union-Tee	143	2004804 Cylinder Gasket Kit D. 75		
46	4398686 Seeger Ring D. 60	95	4198951 Regulator	144	4399865 Self-Locking Nut M12		
47	3007843 Roller D. 16 x 25 x 16	96	4199026 Connection	145	4398753 Washer D. 12.5 x 30 x 3		
48	4299523 Piston D. 60	97	4198703 Safety Valve 3/8" 11 Bar	146	3006649 Cylinder Shaft R.H.		
49	4299524 Cylinder Liner D. 60	98	4298308 Pressure Gauge D. 40				

Parts Identification

Part Description		Part Description		Part Description	
Ref No.	Description	Ref No.	Description	Ref No.	Description
147	3008334 Screw M 8 x 369	196	3002161 Pedal Box Base	245	3009062 Cable-Holder U-bolt
148	4397678 Nut M 8	197	3002157 Reverser Control Pedal	246	6609063 U-bolt Support
149	3007941 Screw TE M 8 x 369	198	3000142 Pedal Control Spring	247	4398708 Screw 6 x 16 8.8
150	3002294 Front Flange	199	4399863 Washer 8 x 24 x 2	248	4399120 Screw TSPEI M 10 x 20
151	3002293 Back Flange	200	3003095 Pedal Alignment Pin L.337	249	3008794 Bead Loosener Spacer
152	3002531 Tilting Valve	201	3002159 Jaws/Bead Loosener Control Pedal	250	4398273 Self-Tapping Screw TCEI 5.5 x 19
153	2002530 Turntable Valve	202	4399298 Screw M 8 x 16	251	4398751 Washer 14 (16 x 42 x 3)
154	2006297 Bead Loosener Valve Unit	203	3000139 Pedal Spacer MM.23	252	3000181 Washer
155	3002928 Spiral D. 6/4 L=120 Tubing	204	3002160 Tilting Control Pedal	253	3008858 Cylinder Liner L=405
156	3000599 Pin L=50	205	3008811 Cylinder Back Flange	254	4399947 Washer 8 (9 x 32 x 4)
157	3000146 Rilsan Hose D. 6 x 4 L=750	206	3009460 Cylinder Liner D.200	255	3000495 Washer Ø .10 x 36 x 5
158	3199599 Seeger Ring D-30	207	8183605 Bootie, Lift, Tool, Pkg of 10	256	3000206 Articulation Pin
159	3002901 20" Turntable Cyl. Rod L=401	208	4398289 Washer D.18	257	3002940 Vertical-Arm Plate
160	3007817 19/20" Turntable Slot Cover	209	2009091 D. 200 Cylinder Sealing Kit	258	4299952 Handle D.12
161	4399981 Washer 12 (13 x 24 x 2.5)	210	3005809 Cylinder Limit Stop D.200	259	4398901 Screw 10 x 20 Uni 5739
162	4399864 Seeger Ring D. 12	211	3007781 Fixing Plate	260	4397375 Screw TCEI M 12 x 140 8.8
163	3006879 Turntable Spacer	212	3006496 Washer 18 x 90	261	3008084 Tilting Cylinder Liner L=131
164	3006880 Connecting Rod Spacer	213	3008992 Pressure Regulator Bracket	262	3008085 Special Screw M 8 x 160
165	3002341 Ring D. 60	214	4399300 Screw M6 x 12 8.8	263	3008860 Stud Bolt M 8 x 1.25 x 437
166	4398838 Screw M 12 x 1.25 x 45	215	3007852 Piston Rod D.20 L=530	264	3008859 Cylinder Shaft D.20 L=458
167	4197938 Aluminum Washer 1"	216	3008812 Tie Rod M10 L=260	265	3002624 Cylinder Rod L=307
168	4399890 Screw M 6 x 20 8.8	217	2109011 Cylinder Front Flange	266	4397649 Screw TE M 6 x 50 8.8
169	4199161 Cap 2611 1/8"	218	4198285 5-ways Valve	267	3008991 GT-Hose Fixing Plate
170	2011328 GT Inflation Valve	219	4399299 Screw 6 x 30 8.8	268	4399894 Belleville Washer 8.2 x 18 x 1
171	4399889 Nut M 6	220	4297978 Handle Casing	269	4399891 Self-Tapping Screw 2.9 x 6.5
172	3010287 GT Pedal Support	221	3010284 Metal Handle	270	3006877 Slide Shim
173	4398890 Screw 6 x 45 x 4.8	222	4397401 Flange Nut M 10	271	2107487 Sliding Guide
174	4298942 Spring D. 20 x 26	223	3001996 Screw	272	4398037 TCEI Screw M 10 x 1.25 x 25 10.9
175	4398107 Screw TE 16 x 180 UNI 5737	224	4298992 Rotating Union Tubless	273	3002297 Locking Clamp
176	4399892 Screw M 6 x 20 8.8	225	4399207 Lubricator Fitting M 6	274	2107387 GT Slide
177	3008005 Limit Stop Screw Support	226	4298802 O-ring	275	8183602 9010 Operating Instructions
178	2110288 GT Pedal	227	3006773 Pedal Return Spring 14 x 10	276	3007935 Shock Absorber
179		228	3002447 Connecting Rod	277	3007934 Shock Absorber Seat
180	3000141 Inflation Valve Spring	229	4599915 IH Reverser 25A	278	4199098 Union 6500 1/8" 6-4
181		230	3000175 Reverser Lever	279	4199610 Silencer 1/8"
182	4399828 Washer D. 16	231	4399045 Toothed Washer 3.2 x 12 x .5	280	4199172 Union 6463 1/8" 6
183	4399969 Nut M 10	232	4399905 Screw M 4 x 12 8.8	281	4198618 Union 6520 1/8" -6 90° Elbow
184	2108798 Slide	233	3009778 Washer	282	2008332 Cylinder Right Helper
185	3001853 Valve Control Lever	234	4399926 Screw M 16 x 1.5 x 40 8.8	283	4197390 Hose Clamp D.8 x 13 H9
186	4399880 Screw M 10 x 40 8.8	235	3000062 Turntable Cap	284	4198766 Connection 1/8" - 8
187	2008060 20" Cylinder Assembly	236	4399966 Screw M10 x 20 x 8.8	285	4199026 Connection
188	3000164 Belt Stretcher Shoe	237	3002311 Washer D. 10 x 48 x 5	286	3002353 Divider for Inflation Unit
189	8183711 Power Cable, Molded	238	4397454 Screw TCEI M 20 x 90 8.8	287	2009045 GT Inflation Hose L=1500
190	4398783 Spring Pin D.4 x 24	239		288	4299354 Relief Pushbutton
191	4299912 Connecting Rod	240	4399810 Nut M 20 Low	289	4399256 Washer 1/4" D.13 x 19 x 1.5
192	4299911 Forked Leaf Spring	241	4398672 Screw 6 x 16 Uni5933	290	8107985 Flanged Air Gauge w/Fasteners
193	4299910 Connecting Rod Guide	242	3000174 Reverser Cover	291	4197718 Union 6520 M 5 x 4, 90°
194	4299913 Double Cam	243	3008171 Roller	292	4197703 Set Screw M 10 x 12
195	3002445 Support-Switch	244	4397661 Parallel Pin 12 x 80		* Indicates Accessory Item

Parts Identification

Part		Part		Part	
Ref	No.	Description	Ref	No.	Description
293	4197743	Union 6511 M 5 x 4	342	4197704	Union 1/8" F-4 90°
294	4197740	Union 6430 1/8" x 4	343	4198921	Union M/F 1/8"
295	4197741	Union 6500 1/8" - 4	344	3007990	Rilsan Hose 4 x 2 L=220
296	3009014	Limit Stop Spring L.H.	345	3007988	Rilsan Hose 4 x 2 L=1200
297	4198035	Brass Union PC 10-02	346	3009093	U-bolt Support
298	2108782	U-bolt R.H.	347	3009092	Hose D.6 x 12 L=200
299	2108784	Set Screw R.H.	348	3001630	Rilsan Hose 6 x 4 L=960
300	4198888	Union PST 10-01 1/8"-10	349	3002709	Rilsan Hose 6 x 4 L=157
301	3008042	Cylinder Liner	350	3000143	Rilsan Hose 6 x 4 L=480
302	4198898	Union 1/8" 8-6	351	3000218	Rilsan Hose 6 x 4 L=1100
303	4198870	Double Union 1/8" 8-6	352	3006478	Polyurethane Pipe Ø.10 L=310
304	2008711	20" GT Turntable Assembly	353	3006477	Hose 10 x 6.5 L=335
305	4199789	Union 1510 1/8" 8-6	354	3002226	Rilsan Spiral Hose 8 x 6 L=430
306	9209612	Clamp Cover	355	3002225	Rilsan Spiral Hose 8 x 6 L=320
307	2008857	Cylinder Group	356	3099335	Rilsan Hose 8 x 6 L=740
308	4397527	Screw 8 x 30 10.9	357	3002183	Rilsan Hose 14 x 11 L=970
309	4198954	Union 6510 1/8" -8	358	3001182	Rilsan Hose 8 x 6 L=250
310	2009095	Double Union Group	359	3001342	Rilsan Hose 8 x 6 L=1000
311	4198778	Union 6410 1/8" - 8	360	3002446	Rilsan Hose 8 x 6 L=100
312	4198884	Union 6510 1/4" -8	361	3000218	Rilsan Hose 6 x 4 L=1100
313	4198853	One-way Valve 1/4"	362	3000217	Rilsan Hose 6 x 4 L=840
314	4199843	Silencer Outlet Adjuster 1/8"	363	3000218	Rilsan Hose 6 x 4 L=1100
315	4198888	Union PST08-01 1/8" -8, Tee	364	3000889	Rilsan Hose 8 x 6 L=1100
316	3009013	Limit Stop Screw Support L.H.	365	3001383	Rilsan Hose 8 x 6 L=500
317	4399951	Bolt M 10 x 35 8.8	366	3002110	Rilsan Hose 8 x 6 L=580
318	2008881	Bead Loosener Double Eff. Cyl.	367	3002601	Mounting Head Shock Absorber
319	4198298	6501 Unit 1/4" -6 S.R.	368	3099339	Rilsan Hose
320	4199098	Union 6500 1/8" 6-4	369	4399378	Washer D. 10 (10,5 x 21 x 2)
321	4399946	Screw M8 x 16 8.8	370	8182037	Nylon Tube 1/4" OD x 10" Lg.
322	4198883	Union 6500 1/4" -90°	371	8103649	Ø1/4" x 12" Hose
323	3000670	Union, Manifold	372		
324	8182035	Male St Fit: 1/8 NPT x 1/4 Tube	373	3009004	Rilsan Hose 6,35 x 1 L=330
325	8111083	Regulator	374	4399044	GT Slide
326	8109472	1/8" Inline Filter	375	4197629	Nylon Washer 1/8"
327	8110496	Volume Chamber	376	4398144	Nut M 18 Uni 5588
328	8109471	1/8" Brass Hex Nipple	377	3007953	Bush D.18 x 12,5 x 21
329	8101428	Hose Clamp-1/4 I.D. Hose	378		
330	8111255	Spl Tee-1/4 NPT x 3/8 x 1/4 Tube	379	4297520	O-ring 153 D.49,21 x 3.53
331	8109466	Valve-Piloted	380		
332	8110325	1/4" NPT Male Run Tee	381		
333	8183612	Reduction	382	3099338	Rilsan Hose D.8 x 6 L=170
334	8109468	Pressure Repeater	383	3008646	O-ring Spacer (D. 55 x 1,5)
335	8110497	Fitting-90 Deg. Male Elbow	384	4399932	Seeger Ring D.65
336	4198993	Union 6510 1/8"	385	2107488	Pin Sliding Guide
337	2008083	Tilting Cylinder+Shock Absorber	386	2007849	Robot Control Group
338	4198531	Screw TCEI M 20 x 90 8.8	387	3008915	Hose Guide
339	4198882	Unit 1/4" -6 s. Quick, 90°	388	4399378	Washer D. 10 (10,5 x 21 x 2)
340	4198642	Sleeve Collar F 1"	389	4399971	Self-Locking Nut M 10
341	4198884	Union 6510 1/4" -8	390	4399827	Screw M 8 x 20 8.8
391			391		
392	4398850	Set Screw M 10 x 12	392	4398850	Set Screw M 10 x 12
393	4398849	Set Screw M 10 x 16	393	4398849	Set Screw M 10 x 16
394	3007801	Mounting Head	394	3007801	Mounting Head
395	2007802	Mounting Head Assembly	395	2007802	Mounting Head Assembly
396			396		
397	4399953	Screw M 10 x 16 8.8	397	4399953	Screw M 10 x 16 8.8
398	9209611	Plastic Insert, Mount Demount Head	398	9209611	Plastic Insert, Mount Demount Head
399	3000215	Peak Roll	399	3000215	Peak Roll
400	4398854	Dowel Pin 5 x 20	400	4398854	Dowel Pin 5 x 20
401	4399121	Screw 6 x 6	401	4399121	Screw 6 x 6
402	4397702	Screw TCEI M 5 x 12 8.8	402	4397702	Screw TCEI M 5 x 12 8.8
403			403		
404	4399949	Self-Locking Nut M14	404	4399949	Self-Locking Nut M14
405	4198908	Union 2020 1/4" F/M 90°	405	4198908	Union 2020 1/4" F/M 90°
406	4199726	Nipple 1/4"	406	4199726	Nipple 1/4"
407	4198143	Valve 400 1/4" F-F	407	4198143	Valve 400 1/4" F-F
408	4198721	Reduction 1" M-1/4" F	408	4198721	Reduction 1" M-1/4" F
409	4199254	Plug	409	4199254	Plug
410	4399893	Self-Locking Nut M 6	410	4399893	Self-Locking Nut M 6
411			411		
412	4399829	Washer M 8 (8.4 x 16 x 1,5)	412	4399829	Washer M 8 (8.4 x 16 x 1,5)
413	2008402	Nylon Mount/Demount Head Kit	413	2008402	Nylon Mount/Demount Head Kit
414	8183606	Bootie Kit, Shoe, Pkg of 2	414	8183606	Bootie Kit, Shoe, Pkg of 2
415	9208624	M/C Clamp Kit (Set of 4)	415	9208624	M/C Clamp Kit (Set of 4)
416	4399378	Washer D. 10 (10,5 x 21 x 2)	416	4399378	Washer D. 10 (10,5 x 21 x 2)
417	8182373	Decal, Warning	417	8182373	Decal, Warning
418	8182768	Caution Decal-B.L.	418	8182768	Caution Decal-B.L.
419	8109888	Inflation Warning Decal	419	8109888	Inflation Warning Decal
420	8180237	Caution Decal	420	8180237	Caution Decal
421	8109769	Decal, Release Valve	421	8109769	Decal, Release Valve
422	8181232	Decal - Lubricator	422	8181232	Decal - Lubricator
423	8140963	Decal - CSA Caution	423	8140963	Decal - CSA Caution
424	8181587	Circuit Breaker	424	8181587	Circuit Breaker
425	8183698	9010 Service Manual	425	8183698	9010 Service Manual
426	3008403	Nylon Mount/Demount Head (Single)	426	3008403	Nylon Mount/Demount Head (Single)
480	2110305	Metal Protector - Handle	480	2110305	Metal Protector - Handle
481	4398807	Washer M14	481	4398807	Washer M14
482	4399100	Split Pin (Roll Pin)	482	4399100	Split Pin (Roll Pin)
				*	Indicates Accessory Item

Parts Identification

WIRING DIAGRAM

DOMESTIC C.S.A. EXPORT

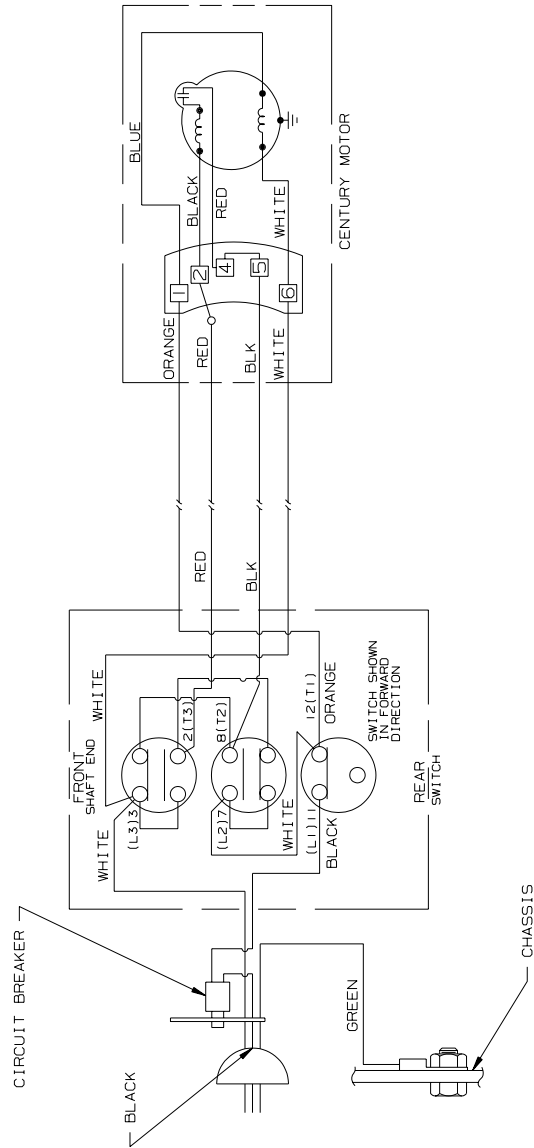

TO REVERSE ROTATION INTERCHANGE THE RED AND BLACK WIRES

Rim Clamp® Tire Changer

All-Air Unit Compressed Air Requirements

COATS® Rim Clamp® tire changers that are powered entirely by air (no electric motor) require a single compressed air power source. Refer to the table below for exact specifications.

Tire Changer Model	Compressor Size	Capable of
9010A	5 HP	14-15 SCFM at 150 PSI

Oiler and Water Separator Maintenance

The oiler and water separator (on units so equipped) require weekly service. Oil and water levels (indicated on the level gauge on the side of each bowl) should be checked regularly

1. On units without automatic drain (manufactured before August 1996), drain the water from the separator by unscrewing the petcock on the bottom of the bowl. Allow water to drain and tighten petcock securely by hand.

2. Add oil to the oiler if the fluid level is more than 1/4" from the top of the gauge. Remove the filler plug in the top of the oiler, and add SAE 10W non-detergent oil or an air tool oil to bring the level up to 1/4" from the top of the gauge. Replace the filler plug and clean up any spilled oil.

3. On units manufactured before August 1996, adjust the oil flow by pulling the red flow adjustment ring up and turning it to increase or decrease the flow. Push the ring down to lock. Watch the formation of oil drops in the see-through oil chamber. Continually cycle the bead loosener through full strokes and count the drops during the cycles. The delivery of oil to the air line should be about 1 drop per 10 cylinder cycles. Adjust the flow as required.

Note: An alternate adjustment method for the oil flow is to turn the knob fully clockwise to stop the flow, then turn it back counterclockwise 1/4 turn.

Transmission Lubrication

The transmission in this machine is a sealed unit packed with grease and should need no regular maintenance.

Air Gauge Check and Recalibration

1. Inflate a standard 15" passenger car tire/wheel assembly to 32 PSI. Use a high quality stick-type pressure gauge to verify the pressure. Attach the tire changer's inflation hose to the valve stem and check the pressure reading on the air gauge. If it does not read 32 PSI, recalibrate the gauge.

2. Remove the screw-on lens. Loosen the 2 screws on the face of the gauge. Loosen them just enough so that the gauge face moves. Do not remove the screws.

3. Rotate the gauge face until the 32 PSI mark is aligned with the gauge needle. Tighten the 2 screws and replace the lens.

Danger, Warning, Caution, and Instructional Decals

Always make the cleaning of these important decals a part of your regular maintenance routine. If they are damaged or illegible, replace them immediately. Your safety, and the safety of others is involved!