



# 4000SP

## Drum & Disc **BRAKE LATHE**



### **Installation Instructions Operating Instructions Safety Instructions Maintenance Instructions *with Parts Identification***

READ these instructions before placing unit in service. KEEP these and other materials delivered with the unit in a binder near the machine for ease of reference by supervisors and operators.

***HENNESSY INDUSTRIES, INC.***

1601 J. P. Hennessy Drive, LaVergne, TN USA 37086-3565 615/641-7533 800/688-6359

HENNESSY INDUSTRIES INC. Manufacturer of AMMCO®, COATS® and BADA® Automotive Service Equipment and Tools.

Manual Part No.: 941413 00

Revision: 01/06



# Contents

## Table of Contents

<b>Safety Notices and Decals</b> .....	<b>iv</b>
<b>Warning</b>	
Cautions and Dangers .....	iv
<b>Owner's Responsibility</b> .....	<b>v</b>
<b>Definitions of Hazard Levels</b> .....	<b>v</b>
<b>General Safety Instructions</b> .....	<b>vi</b>
<b>Before You Begin</b>	
Receiving .....	1
Electrical Requirements .....	1
Installation .....	1
Preparation for Use .....	2
Operating Specifications .....	2
Principle Operating Parts .....	3
<b>Operating Instructions</b>	
Arbor Installation .....	4
Adapters .....	4
Basic Operation .....	4
Poly V-Belt Tension and Adjustment .....	5
Basic Operation of Handwheels .....	5
<b>Reconditioning Brake Drums</b>	
Preparation .....	5
Mounting Drums .....	6
<b>Reconditioning Disc Brake Rotors</b>	
Preparation .....	8
Twin Cutter .....	8
6950 Twin Cutter .....	8
Rotor Mounting .....	9
Set Up and Reconditioning Rotors .....	10
<b>Maintenance and Service</b>	
Oiling .....	12
Cleaning .....	12
Care of Arbors and Adapters .....	12
Shear Gear Replacement .....	13
<b>Parts Identification</b>	
Spindle .....	14-15
Motor Mount and Drive Shaft .....	16-17
Crossfeed Assembly .....	18-19
Disc Brake Feed Mechanism, #7751 .....	20-21
Drum Feed Gearbox Assy. 3037 .....	22-23
6950 Twin Cutter .....	24
Electrical Panel Assembly .....	25

# Safety

## Safety Notices and Decals

For your safety, and the safety of others, read and understand all of the safety notices and decals included here and on the unit.

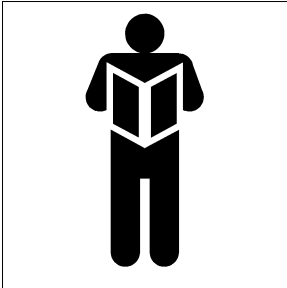

**Read entire manual before installing, operating, or servicing this equipment.**

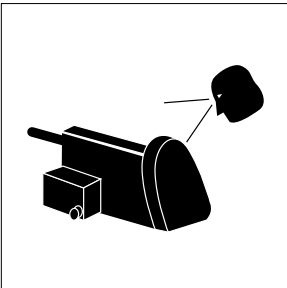

**Proper maintenance and inspection is necessary for safe operation.**



**Do not operate a damaged lathe.**

## Warning

This equipment incorporates parts such as snap switches and power receptacles which tend to produce arcs or sparks. Therefore, when located in a service facility, the unit should be in a room or enclosure provided for the purpose, or should be at least 18" or more above floor to minimize the risk of igniting fuel vapors.

## Cautions and Dangers

1. Eye and face protection requirements:

"Protective eye and face equipment is required to be used where there is a reasonable probability of injury that can be prevented by use of such equipment." OSHA 1910.133 (a).

Protective goggles, safety glasses, or a face shield must be provided by the purchaser/user and worn by the operator of the equipment. Make sure all eye and face safety precautions are followed by the operator(s). Keep bystanders out of the area.

2. Do not remove any safety equipment, belt guards, or shortcut controls or operations.
3. Make sure drums and rotors are properly and squarely mounted before starting lathe, and that all parts are secure.
4. Do not wear loose clothing, jewelry, or gloves when operating or working around a lathe.
5. Do not overload the lathe. Read and understand the lathe specifications. Overloading is poor machine tool practice, shortens the life of the lathe, and could cause a failure resulting in personal injury.



**Failure to follow danger, warning, and caution instructions may lead to serious personal injury or death to operator or bystander or damage to property. Do not operate this machine until you read and understand all the dangers, warnings and cautions in this manual. For additional copies of either, or further information, contact:**

## **Hennessy Industries, Inc.**

1601 J.P. Hennessy Drive  
LaVergne, TN 37086-1982  
(615) 641-7533 or (800) 688-6359  
[www.ammcoats.com](http://www.ammcoats.com)

# Safety

## Owner's Responsibility

To maintain machine and user safety, the responsibility of the owner is to read and follow these instructions:

- Follow all installation instructions.
- Make sure installation conforms to all applicable Local, State, and Federal Codes, Rules, and Regulations; such as State and Federal OSHA Regulations and Electrical Codes.
- Carefully check the unit for correct initial function.
- Read and follow the safety instructions. Keep them readily available for machine operators.
- Make certain all operators are properly trained, know how to safely and correctly operate the unit, and are properly supervised.
- Allow unit operation only with all parts in place and operating safely.
- Carefully inspect the unit on a regular basis and perform all maintenance as required.
- Service and maintain the unit only with authorized or approved replacement parts.
- Keep all instructions permanently with the unit and all decals/labels/notices on the unit clean and visible.
- Do not override safety features.

## Definitions of Hazard Levels

Identify the hazard levels used in this manual with the following definitions and signal words:

### DANGER

Watch for this symbol:



It Means: Immediate hazards, which will result in severe personal injury or death.

### WARNING

Watch for this symbol:



It Means: Hazards or unsafe practices, which could result in severe personal injury or death.

### CAUTION

Watch for this symbol:



It Means: Hazards or unsafe practices, which may result in minor personal injury or product or property damage.



Watch for this symbol! It means BE ALERT! Your safety, or the safety of others, is involved!

<b>⚠ CAUTION ⚠</b> Prevent accidents and injury, read and follow instructions.		
<ol style="list-style-type: none"><li>1. Read and follow instructions.</li><li>2. Always wear eye protection, avoid loose clothing and jewelry.</li><li>3. Keep all guards, shields, and covers in place and in working order.</li><li>4. Keep bystanders out of work area.</li><li>5. Unplug unit from power source before servicing or adjusting.</li><li>6. Maintain unit properly, keep work surfaces and work area clean.</li></ol>		

# Safety

## General Safety Instructions

Before operating the lathe, review the warning information on the lathe and the cautions, warnings and dangers in this manual. Also review the following general safety instructions. Failure to follow safety instructions could result in personal injury to operator or bystanders and damage to the lathe or personal property.

1. Keep guards in place and in working order.
2. Remove adjusting keys and wrenches from the tool before turning it on. Make this a habit.
3. Keep work area clean. Cluttered areas and benches invite accidents.
4. Avoid dangerous operating environments. Do not use power tools in areas where explosive vapors are present or in damp or wet locations. Do not expose them to rain. Keep the work area clean and well lighted.
5. Keep children away. All bystanders should be kept completely away from the work area.
6. Make the workshop kid-proof. Use padlocks and master switches, and remove starter keys.
7. Don't force a tool. It will do the job better and safer at the rate for which it was designed.
8. Use the right tool. Don't force a tool or an attachment to do a job for which it was not designed.
9. Dress properly. Loose clothing, gloves, neckties, shop rags or jewelry may get caught in moving parts. Non-slip footwear is recommended. Wear protective hair covering to contain long hair.
10. Wear eye protection. Safety glasses, goggles, or a face shield will help protect the operator from injury. Use a face shield and dust mask during dusty operations.
11. Secure the work properly to the unit for setup and tool bit positioning. Do not attempt to hold a drum or rotor steady on the arbor with your hands. Both hands must be free to operate unit.
12. Don't overreach. Keep proper footing and balance at all times when lathe is in operation or when working around the unit.
13. Maintain tools with care. Keep tools sharp and clean for best and safest performance. Follow instructions for lubricating and changing accessories.
14. Remove power from the unit and disconnect tools before servicing and when changing accessories such as blades, bits, cutters, etc. Follow lockout and tag-out procedures as required.
15. Avoid unintentional starting. Make sure the switch is in the OFF (O) position before plugging the machine in or performing any maintenance or service work.
16. Use recommended accessories. Consult the manufacturer's catalogs for recommended accessories. Use of improper accessories may cause risk of injury to operator or bystanders.
17. Never stand or lean on a lathe. Serious injury could occur if the lathe is tipped or if the cutting tool is unintentionally contacted.
18. Check damaged parts carefully. Before further use of the lathe, a guard or other part that is damaged should be carefully checked. Immediately replace all damaged, missing, or non-functional parts. Check for alignment of moving parts, binding of moving parts, breakage of parts, mounting, and any other conditions that may affect operation. Guards and other parts that are damaged should be properly repaired or replaced before lathe is used again.
19. Always feed the work into a blade or cutter and against the direction of rotation. Cutters and tool bits are designed to cut from the inside of a drum or rotor to the outer edge. Do not attempt to cut from the outside edge in to the center.
20. Never leave tools running unattended. Turn the power off. Don't leave the tool until it comes to a complete stop.
21. Never use compressed air to blow the tool clean. Chips and dust may be driven between machined parts and into bearings, causing undue wear. They may also contact persons in the area causing personal injury.
22. Operate the lathe in the proper environment. The lathe incorporates parts such as snap switches and power receptacles, which tend to produce arcs or sparks. Therefore, when located in a garage the unit should be in a room or enclosure provided for the purpose, or should be at least 18" or more above the floor to minimize the risk of igniting fuel vapors.

## Before You Begin

### Receiving

The shipment should be thoroughly inspected as soon as it is received. The signed bill of lading is acknowledgement by the carrier of receipt in good condition of shipment covered by our invoice.

If any of the goods called for on this bill of lading are shorted or damaged, do not accept them until the carrier makes a notation on the freight bill of the shorted or damaged goods. Do this for your own protection.

NOTIFY THE CARRIER AT ONCE if any hidden loss or damage is discovered after receipt and request the carrier to make an inspection. If the carrier will not do so, prepare a signed statement to the effect that you have notified the carrier (on a specific date) and that the carrier has failed to comply with your request.

IT IS DIFFICULT TO COLLECT FOR LOSS OR DAMAGE AFTER YOU HAVE GIVEN THE CARRIER A CLEAR RECEIPT.

File your claim with the carrier promptly. Support your claim with copies of the bill of lading, freight bill, invoice, and photographs, if available.

Although AMMCO's responsibility ceases upon delivery of the shipment to the carrier, we will gladly assist in tracing lost shipments. Our willingness to assist in every possible manner does not make AMMCO responsible for collection of claims or replacement of lost or damaged materials. Shipping damage claims will not be handled under warranty.

### Electrical Requirements

The lathe must be properly grounded to protect the operator from shock. The lathe is equipped with an approved 3-conductor cord and a 3-prong grounding type plug to fit the proper grounding-type receptacle. Should an extension cord be required, use 3-conductor cords with 3-prong grounding plug and 3-prong grounding receptacle properly rated to handle this electrical power tool only. Do not modify a cord or plug to match a receptacle; have a qualified electrician install an appropriate outlet to match the lathe requirements. Repair or replace any worn or damaged power cords immediately.

Verify that the lathe plug and grounding-type receptacle match as shown in Figure 1.

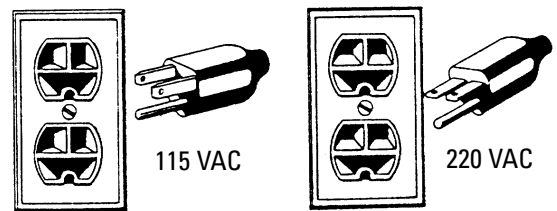

Figure 1 - Power cord plug and receptacle types

### Installation

1. Assemble bench according to the instructions provided. Tighten all fasteners securely.
2. After assembly, the bench should be leveled and may be bolted down with 3/8 or 7/16 inch bolts or lag screws.
3. Unbolt the lathe from the shipping pallet. Lift the lathe onto the bench.
4. Bolt the lathe to the bench with the hardware provided. Tighten fasteners securely.
5. Remove any packing materials and protective wrapping from the lathe and components.
6. Make sure lathe is turned off. Plug lathe into a properly installed and grounded outlet that matches the lathe plug.
7. Remove the shipping plug, insert the oil dipstick, and check oil level. The lathe is shipped with the correct amount and type of oil. Add oil as necessary to reach the correct mark on the dipstick. Use only EP-80-90 gear oil. Oil level should be checked often. See figure 2.
8. Clear the area and turn lathe on. Check for proper operation (motor and spindle rotation).

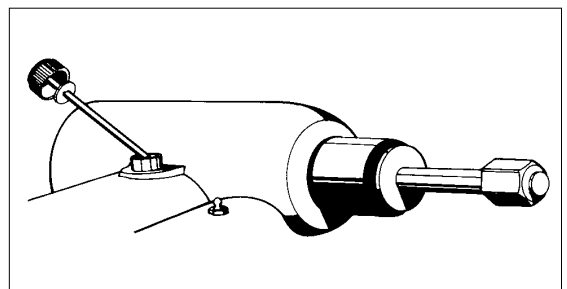

Figure 2 - Check oil level

## Preparation for Use

1. Inspect all adapters and accessories for burrs, nicks, or other damage.
2. Clean accessories with a vaporizing solvent.
3. Apply a light film of oil to all adapters to protect their machined surfaces from rust. Refer to the maintenance section for more information.



**There is a circuit breaker located on the electrical panel to prevent damage to the lathe in the event the motor is overloaded. Move the switch to the off position and correct overloading situation before re-setting circuit breaker. Serious personal injury could result if circuit breaker is re-set while lathe is still on.**

## Operating Specifications

**4000**

Overall Lathe Height . . . . .	17.25" (438 mm)
Lathe Shipping Weight . . . . .	.385 lbs. (175 kg)
Floor Space Requirements - Width . . . . .	.48" (1219.20 mm)
Floor Space Requirements - Depth . . . . .	.34.5" (901.70 mm)
Spindle to Floor . . . . .	.39.375" (1000 mm) (mounted on optional bench)
Electrical requirements	
Standard: 115 VAC, 60 Hz, single-phase, fused at 20 amps	
Optional: 220 VAC, 60 Hz, single-phase, fused at 15 amps	
Spindle Motor . . . . .	.1 HP, 60 Hz, 115/220 VAC
Spindle Travel . . . . .	.6.875" (175 mm)
Spindle Speed . . . . .	.100 RPM
Spindle Feed Speed-Drum . . . . .	.0.005 in/rev
Cross Feed Speed-Rotor . . . . .	.0.002 in/rev
Handwheel Graduations . . . . .	.0.002 inches (0.050 mm)
Maximum Rotor Diameter* . . . . .	.14.5 inches (368.3 mm)
Maximum Rotor Thickness . . . . .	.1.875 inches (47.63 mm)
Brake Drum Diameter	
Minimum: 6 inches	
Maximum: 28 inches	
Maximum drum depth . . . . .	.6.875" (175 mm)
Maximum load	
Standard: 1" Arbor . . . . .	.100 lbs. (45.36 kg)
Optional: 1.875" Arbor . . . . .	.200 lbs. (90.72 kg)

\* The optional No. 6936 Cross Feed Extension increases the maximum rotor diameter to 19 inches (483 mm).

## Principle Operating Parts

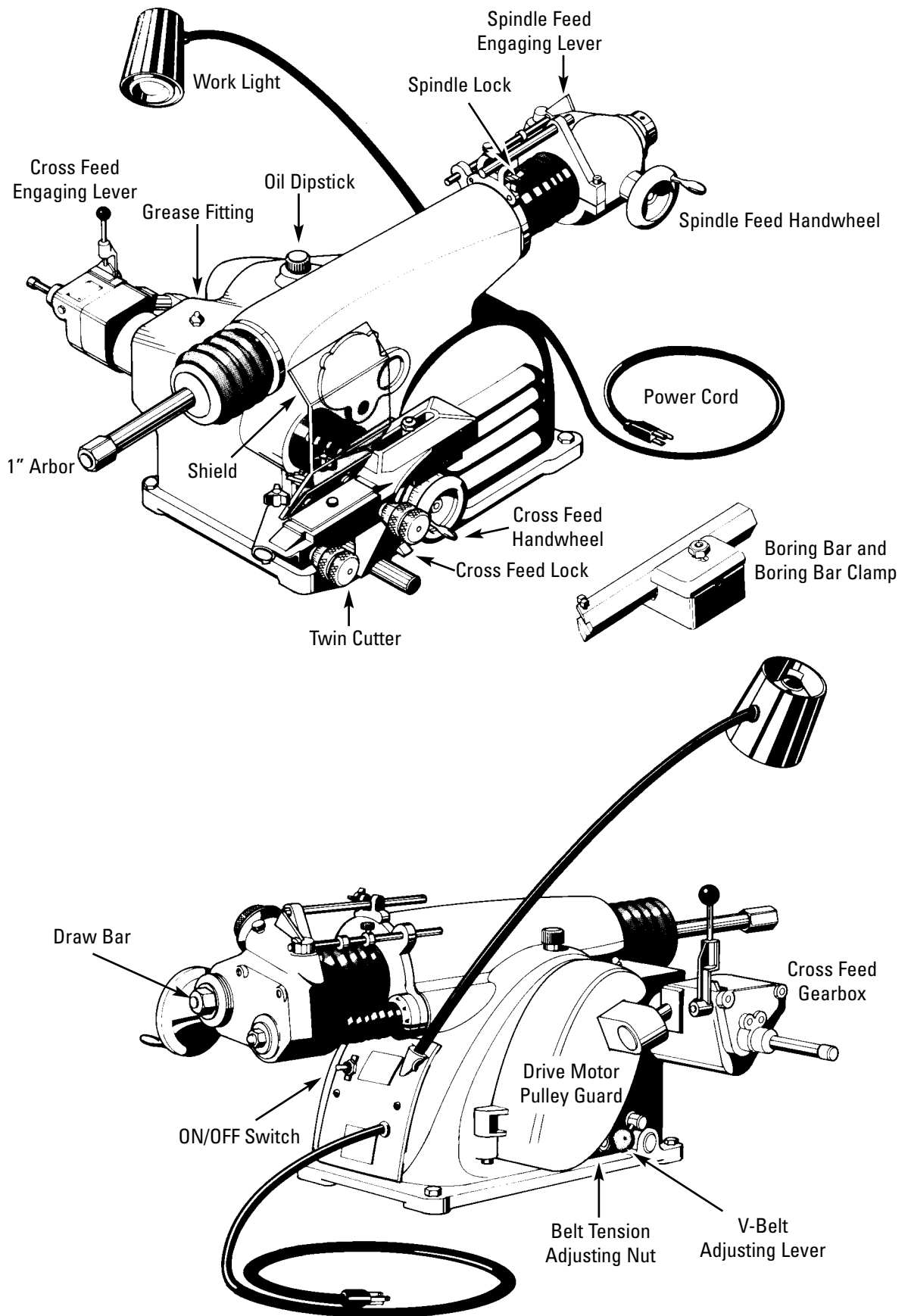

## Operating Instructions

### Arbor Installation

The 1" arbor shipped with the lathe has been carefully matched to the lathe during final assembly and testing. Witness marks have been etched onto the arbor and the spindle for precise, repeatable alignment.

The witness marks must be carefully aligned when installing the arbor (Figure 3). A true-running arbor is essential to professional quality brake drum and rotor reconditioning.

1. Locate the witness marks on the arbor and the spindle.
2. Insert the arbor into the spindle making sure the witness marks are aligned.
3. Tighten the drawbar (located at the rear of the spindle) to pull the hardened and ground tapers of the arbor into the matching seats in the spindle.

### Adapters



**Although the adapters, arbor, and spindle are made of top grade steel and are turned, hardened, and precision ground to close tolerances, great care should be taken in their use, handling, and storage. Even the smallest nick, scratch, or loose chip on the machined mating surfaces can cause incorrect rotor mounting alignment. This will cause inaccurate machining.**

Always inspect the surface, face, and seating tapers of each part before use (figure 4). Wipe each part clean before and after using it. Carefully correct any flaw with a fine stone. If damage cannot be corrected, replace the part.

### Basic Operation

To completely understand drum and rotor turning you must have knowledge of the lathe itself.

**Spindle** — The spindle is a motor driven shaft that turns the arbor upon which the brake drum or rotor is mounted. By turning the drum and holding a cutting tool against the inner braking surface, metal can be removed.



**Do not try to move any feed levers or dials without the drive motor running. Damage may occur to the gear trains.**

**Spindle Feed** — By operating the spindle feed lever, the spindle will move the mounted brake drum to the left. This feeds the braking surface across the cutting tool as the drum moves away from the tool. Spindle feed may also be done manually using the spindle feed handwheel.

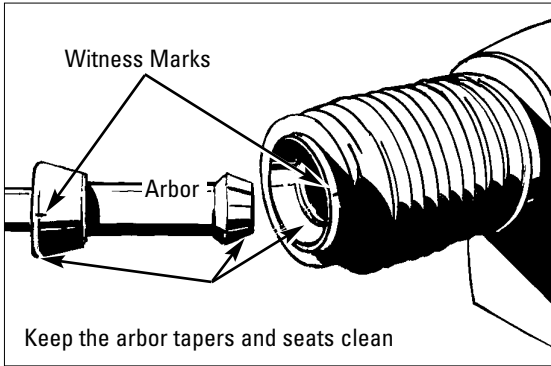

Figure 3 - Align witness marks during arbor installation

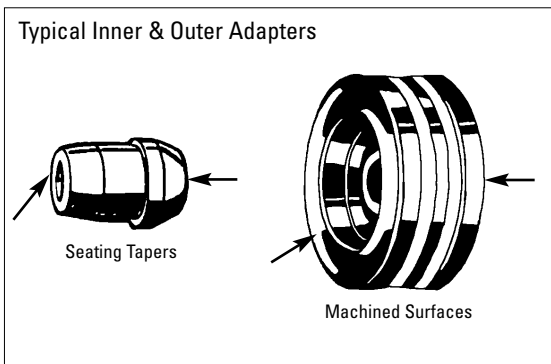

Figure 4 - Use care to avoid damaging mating surfaces

Spindle feed refers to the distance the spindle is pulled per revolution.

**Spindle Speed** — Spindle speed is measured in RPM's. Refer to the specifications listed on page 2 for the RPM rating.

**Cross Feed** — The cross feed draws the tool bit across the face of a brake rotor or flywheel when the cross feed drive is engaged. The cross feed may also be operated manually using the cross feed handwheel.

**Feed Speed** — Feed speed refers to the thousands of an inch the cutting tools move per revolution of the spindle.

### Poly V-Belt Tension and Adjustment

A loose belt can cause slippage when taking heavy cuts. A belt that is too tight can cause vibration and possible sub-standard finishes on machined drums and rotors. Check and adjust belt monthly.

1. Position the poly v-belt speed-adjusting lever to the left (counterclockwise) to the fully engaged position.
2. Loosen the adjustment nut. See figure 5.
3. The poly v-belt should be adjusted to deflect 3/32" with a 5-pound push on the belt. The ideal tension is the lowest tension at which the belt will not slip under the highest load.
4. Retighten the adjusting nut.

Check and adjust as required the tension during the first day of operation. Do not overtighten.

### Basic Operation of Handwheels

Clockwise rotation of the spindle feed handwheel retracts the spindle in towards the lathe.

Clockwise rotation of the cross feed handwheel moves the cutting tool in towards the lathe. Refer to figure 6.

Counterclockwise rotation of the spindle feed handwheel extends the spindle out away from the lathe.

Counterclockwise rotation of the cross feed handwheel moves the cutting tool out away from the lathe. Refer to figure 7.

## Reconditioning Brake Drums

### Preparation

1. Measure the diameter of the brake drum with a brake drum micrometer (figure 8).
  2. Determine if the drum will be within maximum rebore limits after reconditioning.
- NOTE:** Most often, the DISCARD diameter is cast into the brake drum, not the maximum machining diameter.
3. Inspect brake drum. Do not attempt to machine a drum that is damaged or in poor condition.

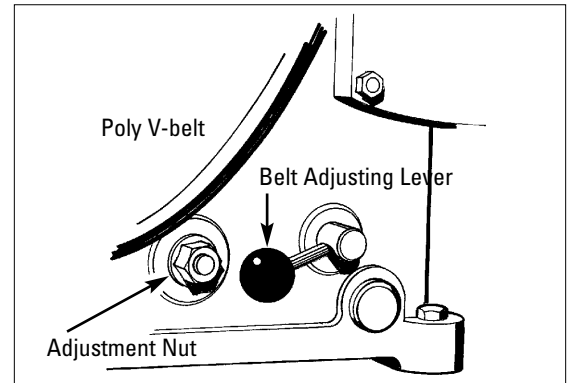

Figure 5 - Engage lever and loosen nut

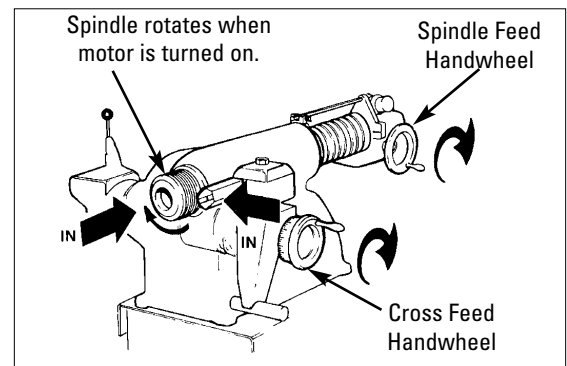

Figure 6 - Clockwise rotation of handwheels

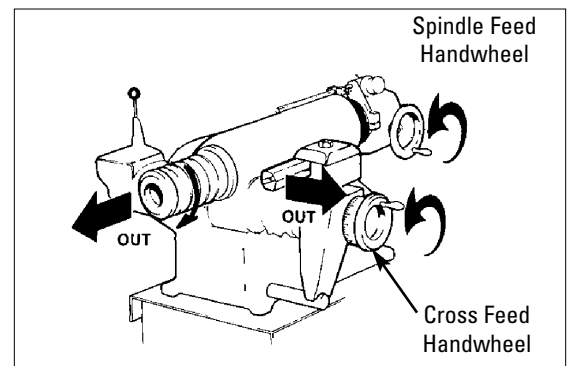

Figure 7 - Counterclockwise rotation of handwheels

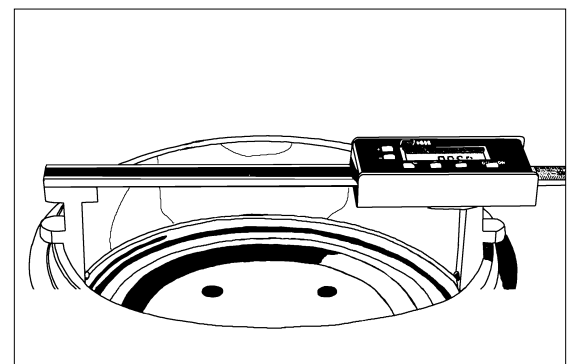

Figure 8 - Measure drum diameter

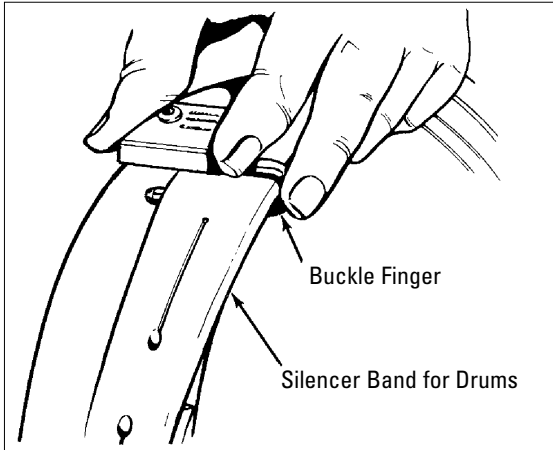

Figure 9 - Attach silencer band

## Mounting Drums

**1.** Loosen the boring bar clamp nut and push the boring bar all the way into the clamp.

**2.** Mount the drum on the arbor using the proper adapters, cones, and spacers. Use examples in Figure 10 for guidance.

**3.** Wrap the drum silencer band snugly around the drum. Be sure it covers up to the right-hand edge (figure 9).

**IMPORTANT:** The spindle feed handwheel will not operate unless the spindle feed engagement lever is in the OFF position. Feed should only be adjusted when the spindle is turning.

**4.** Position the cross slide and spindle by turning their respective handwheels to their maximum clockwise (in) position. Then back off the cross feed handwheel 2 complete turns and the spindle handwheel 4 complete turns.

Figure 10 - Typical drum mounting configurations

**Hubbed Brake Drums** — Tapered cone adapters fit in the bearing seats, making contact near the middle of the bearing race whenever possible rather than near an edge. Various adapters and spacers may be used to fill out the shaft of the arbor.

**Hubless Brake Drums** — A cone fits into the center hole of the drum from the inside to center the drum on the arbor. Select a hubless adapter which will fit inside the drum, against the flat lug hole surface and either straddle the boltholes to avoid mounting against a burr, or remove the burrs. Slip the hubless adapter onto the arbor followed by a spring, the cone, the drum, and another hubless adapter. Fill out the shaft with spacers as needed.

Hubbed Brake Drums

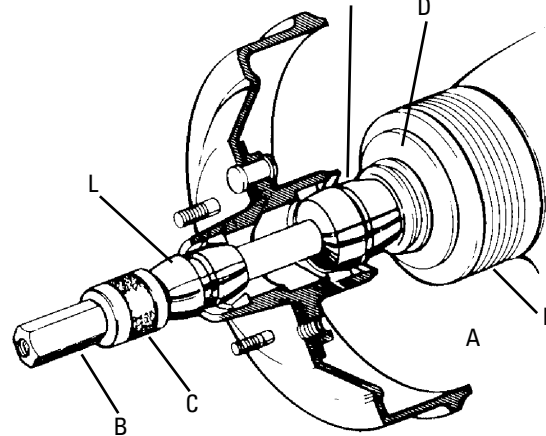

Hubless Brake Drums

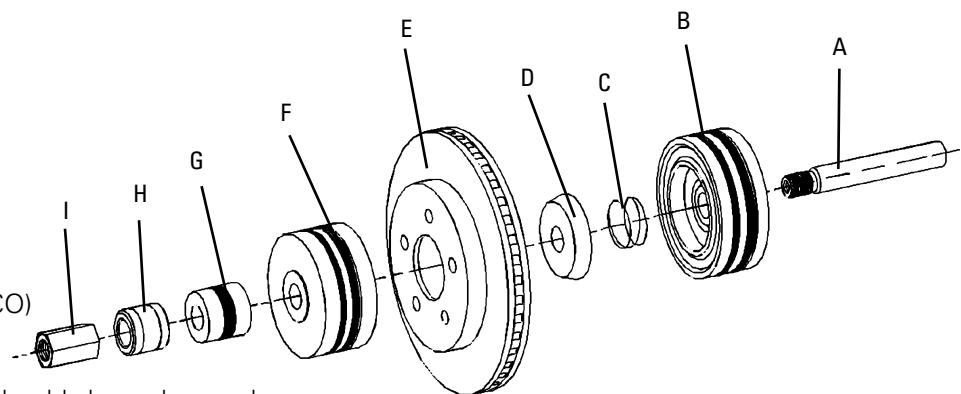

### Key to Mounting Adapters, Cones, and Related Parts

- A. 1" Arbor
- B. Flange Plate
- C. Spring
- D. Centering Cone
- E. Rotor, Drum or Flywheel
- F. Flange Plate
- G. Spacer(s)
- H. Self-Aligning Spacer (AMMCO)
- I. Arbor Nut

**Note:** The self-aligning spacer should always be used next to the arbor nut when tightening. To avoid over-tightening, wrench tighten the arbor nut counterclockwise until the drum and adapters begin to turn on the arbor, then continue to advance the wrench 1/16 of a turn. DO NOT overtighten the arbor nut.

**5.** Position the boring bar by loosening the boring bar clamp nut and sliding the boring bar inward toward the drum until the tool bit is close to the drum (figure 11).

The boring bar position is changed whenever a drum of different diameter is machined.

The entire boring bar clamp may also be swiveled to achieve the best cutting position.

**6.** Turn the drum by hand to make sure that everything is clear.

**7.** Turn the lathe ON.

**8.** Advance the tool bit manually until it just contacts the drum surface momentarily and makes a scratch cut (figure 12).

**9.** Loosen the dial lock screw on the cross feed handwheel and set the dial to the diameter of the drum as measured with the micrometer (figure 13). Tighten the lock screw.

This setting will be the reference used to help determine the drum recondition diameter.

**10.** Back the tool bit off and turn the lathe OFF.

**11.** Loosen the arbor nut, rotate the drum 1/2 turn (180°) on the arbor and inner adapter, and retighten the nut.

**12.** Turn the lathe ON.

**13.** Turn the spindle feed handwheel 1/2 turn in either direction and make a second scratch cut (figure 14).

**14.** Turn the lathe OFF.

**15.** Examine the scratch cuts.

If the first and second cuts are opposite one another (180° apart), remove the drum from the arbor, check the mounting adapters and arbor for nicks, burrs, or chips, remount the drum, and repeat scratch cut process.

If the scratches are side by side, proceed to step 16.

**16.** Turn the spindle feed handwheel until the deepest worn groove of the drum lines up with the point of the tool bit.

**17.** Advance the tool bit into the bottom of the groove by rotating the cross feed handwheel counterclockwise.

**NOTE:** These operations may be done with the lathe running.

The depth of cut dial will show the approximate reconditioned diameter of the drum. This measurement must be compared with:

- A.** The maximum rebores limits cast into the drum.
- B.** The measured diameter to determine the best amount of material to be removed in one pass.

**18.** Determine the depth-of-cut by these general guidelines:

- Roughing cuts should be no deeper than 0.020"
- Finish cuts should be no shallower than 0.004" deep.

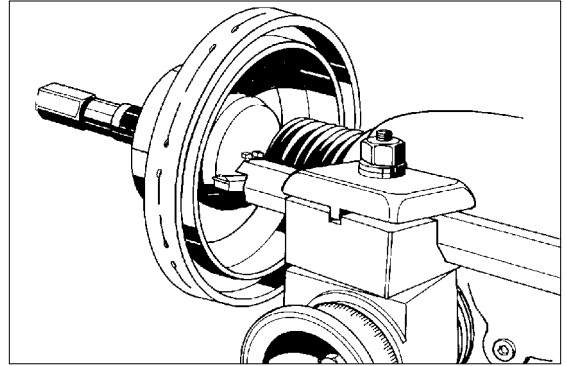

Figure 11 - Positioning the boring bar

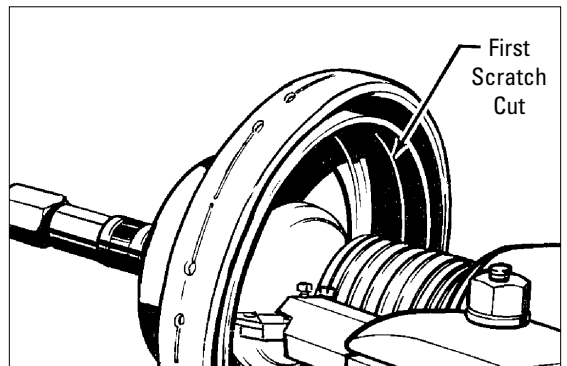

Figure 12 - First scratch cut

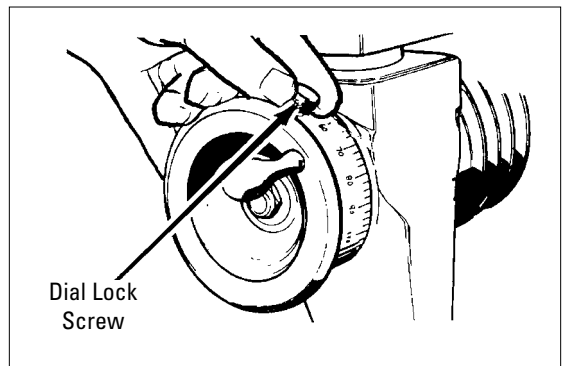

Figure 13 - Set drum diameter measurement

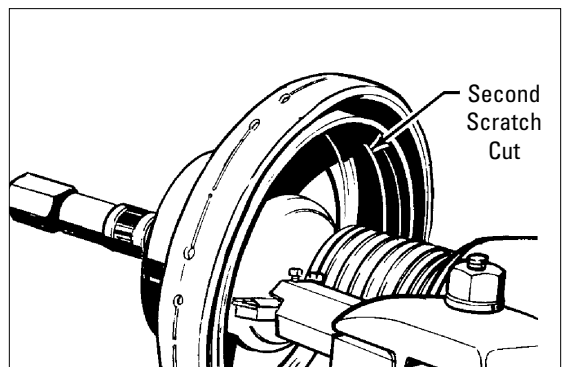

Figure 14 - Second scratch cut

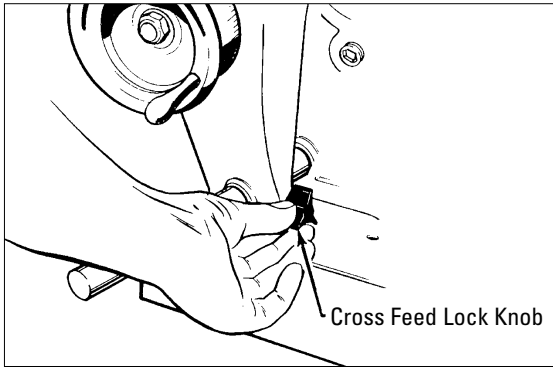

Figure 15 - Lock cross feed

**19.** With the lathe running, set the depth-of-cut dial to the depth desired and lock the cross feed by tightening the lock knob (figure 15).

**20.** Set the feed shut-off by sliding it on the shaft to a point that approximately equals the depth of the drum and tightening it in place (figure 16). The feed will stop when it reaches this point.

**21.** Engage the feed lever to begin drum reconditioning.

## Reconditioning Disc Brake Rotors

### Preparation

**1.** Inspect the rotor carefully for scoring, rust ridges (at the inner and outer circumference of the rotor), and hard spots. Any excessive wear or deformity should be noted and, if not within acceptable limits, the rotor should be replaced.

**2.** Use a micrometer to check the thickness of the rotor (figure 17) at no less than 3 points around the circumference about 1" (2.54 mm) in from the outer diameter.

If the rotor thickness varies between readings, it should be reconditioned. However, if the thickness is less than the minimum established by the manufacturer, or if it will be less after reconditioning, the rotor should be replaced.

**NOTE:** Most often the DISCARD thickness dimension is cast or stamped into the rotor, not the minimum machine-to thickness.

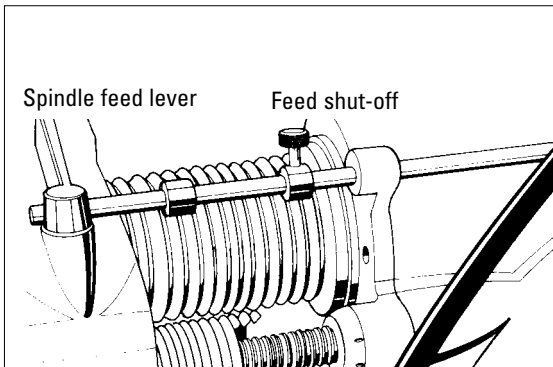

Figure 16 - Set spindle feed shut-off

### Twin Cutter

A twin cutter tool is used to recondition both surfaces of a brake rotor at the same time. The twin cutter replaces the boring bar on top of the cross feed after removing the upper and lower tool bar clamps.

#### Model 6950 Twin Cutter

**1.** Mount the twin cutter on the cross feed with the stud bolt extending through the cast slot (see figure 18). The slot helps center the twin cutter to the rotor.

**2.** Secure the twin cutter to the cross feed with self-aligning nut and washer assembly. Tighten the nut firmly.

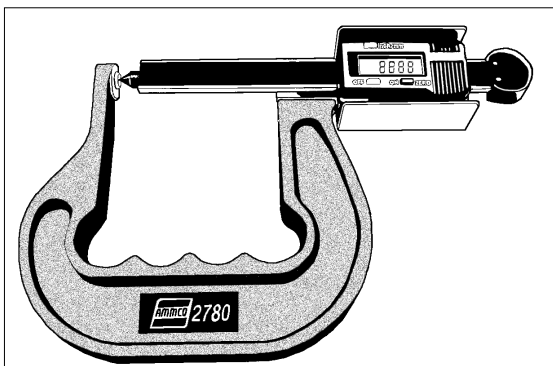

Figure 17 - Measure rotor thickness

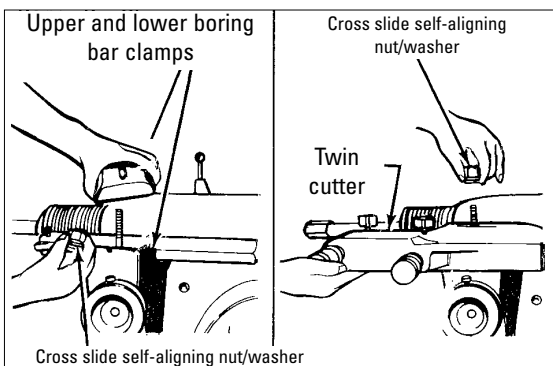

Figure 18 - Install the twin cutter

## Rotor Mounting

Review the descriptions of mounting a brake drum on page 6. The same directions apply when mounting a brake rotor. Hubbed rotors are mounted on adapters that fit into the bearing races. Hubless rotors use a cone in the center hole and a hubless adapter on each side of the rotor. Spacers are used to fill out the arbor shaft so that the arbor nut can be tightened. The setups illustrated in Figure 19 are typical of the many mounting configurations necessary to meet the requirements of brake rotor reconditioning. The adapters, cones, and spacers supplied with the lathe

will allow reconditioning of the majority of the rotors found on current production vehicles. Optional adapters, cones, and spacers are available to meet special needs.

**NOTE:** Adapters may also be used as spacers to fill out the arbor shaft if care is taken to prevent damage to their machined surfaces.

The patented self-aligning spacer prevents diagonal thrust on the adapters. The self-aligning spacer should always be used adjacent to the arbor nut.

Figure 19 - Typical rotor mounting configurations

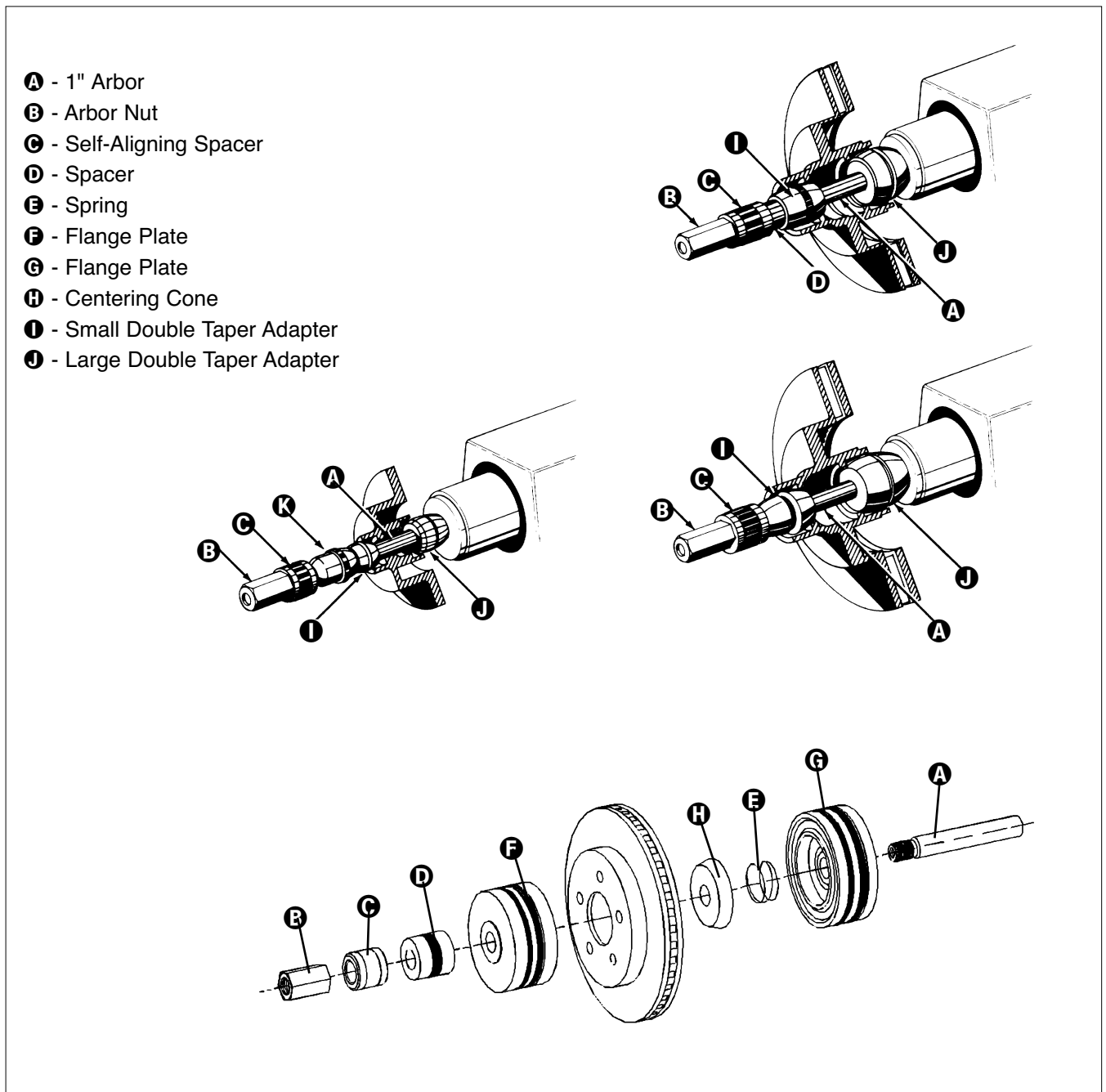

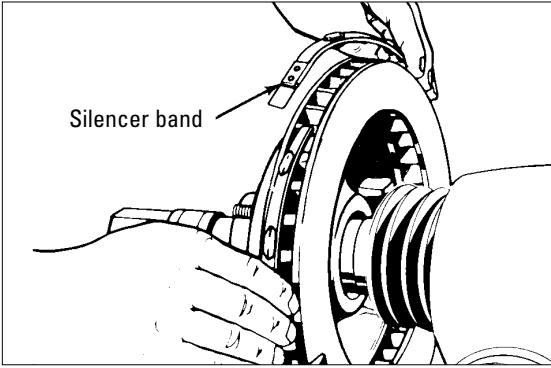

Figure 20 - Attach silencer band

## Set Up and Reconditioning Rotors

**1.** Install a silencer band on the mounted rotor. Stretch the band around the rotor and hook the metal loop over a lead weight. Refer to figure 20.

**2.** Center the twin cutter to the rotor (figure 21). Loosen the stud nut and adjust the twin cutter so that the rotor is centered between the tool bits. The slot of the twin cutter should be approximately parallel to the lathe spindle. Tighten the stud nut firmly.

**3.** Install the safety shield as shown in figure 22. Review the cautions and dangers section and the general safety information at the beginning of this manual. The safety shield is easily screwed onto the twin cutter in the threaded mounting hole provided.



**Always wear safety glasses or a face shield. Cutting or grinding on an exposed surface such as a rotor will produce flying chips and debris.**

**4.** Attach the optional 7075 Pad Silencer and the Clip-on Silencer as needed for composite rotors.

**5.** Make sure that the tool bits clear the rotor surfaces and the silencer band. Give the rotor a full turn by hand and watch for clearance all the way around.

**6.** Turn the lathe ON.

**7.** Turn each tool bit control (the outer knurled knobs, figure 23) clockwise until the tool bits just contact the rotor surfaces.

**8.** When the tool bits make contact, rotate each of the inner depth-of-cut collars to zero and back the tool bits away from the rotor.

From this point on, all tool adjustments will be made with the tool bit controls. Then inner depth-of-cut collars will be the reference and should not be moved.

**9.** Turn the cross feed handwheel until the tool bits are at mid-point of the rotor face.

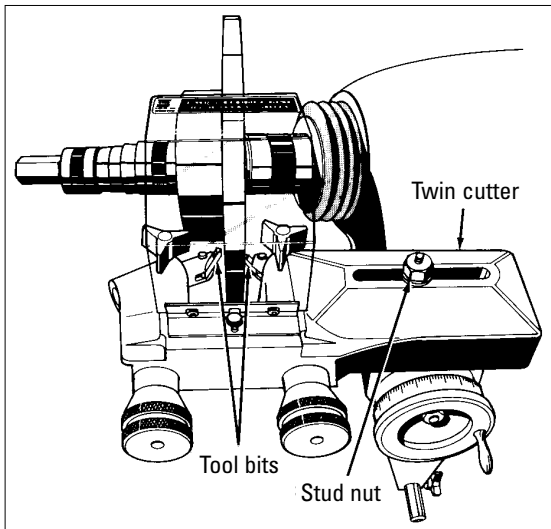

Figure 21 - Center the twin cutter

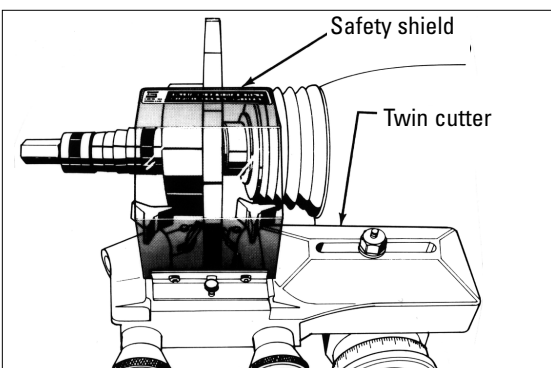

Figure 22 - Attach the safety shield

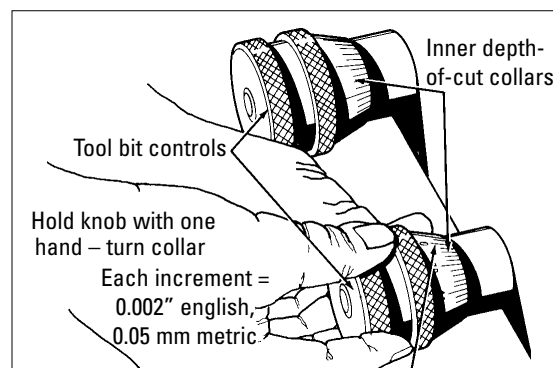

Figure 23 - Tool bit controls

**10.** Turn the left-hand tool bit control until the tool bit contacts the rotor surface and makes a scratch cut (figure 24). After the cut is made, back the tool bits off and turn the lathe OFF.

The scratch will usually appear as an incomplete circle. This is caused by runout or wobble due to rotor condition, or by the way the rotor is mounted on the arbor (figure 25).

**11.** Check rotor mounting by loosening the arbor nut and turning the rotor 180° by hand on the arbor. Make sure the inside adapter does not rotate along with the rotor. Then retighten the arbor nut, turn the cross feed handwheel back 1/2 turn, turn the lathe ON, and repeat step 10 to make a second scratch cut (figure 26).

**12.** If the scratch cuts are side-by-side, the runout or wobble is caused by rotor condition. A dial indicator may be used to compare rotor runout with manufacturer's specifications. See figure 27.

**13.** If the scratch cuts are opposite one another (180°), the rotor may not be properly mounted on the arbor. Remove the rotor and examine the arbor and all adapters for nicks, burrs, chips, dirt, or rust. Inspect the rotor hub for loose or damaged bearing cups. Clean, repair, remount, or replace as necessary.

**14.** Recheck the setting of the depth-of-cut collars, which were set to zero earlier by moving the tool bits inward until they just contact the surfaces of the rotor. The collars should be at zero. Reset the collars if necessary.

**15.** Turn the cross feed handwheel clockwise until the tool bits are near the rotor hub.

**16.** Turn the lathe ON.

**17.** Turn both tool bit controls to the desired depth-of-cut and lock them in position by tightening the red lock knobs above the tool bits.

**18.** Engage the automatic cross feed (figure 28) by moving the lever to the rear of the lathe. The cross feed will stop automatically when the cutting tools have moved all the way across the face of the rotor.

**19.** Exert light pressure inward on cross feed while turning cross feed handwheel slowly clockwise until the leadscrew is engaged.

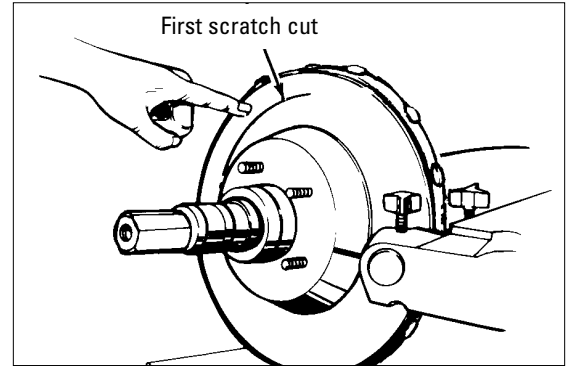

Figure 24 - First scratch cut

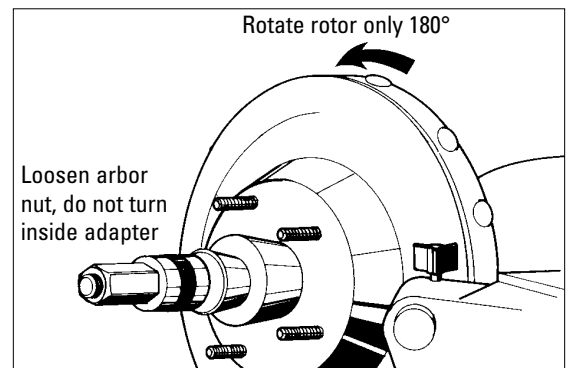

Figure 25 - Rotate rotor 180°

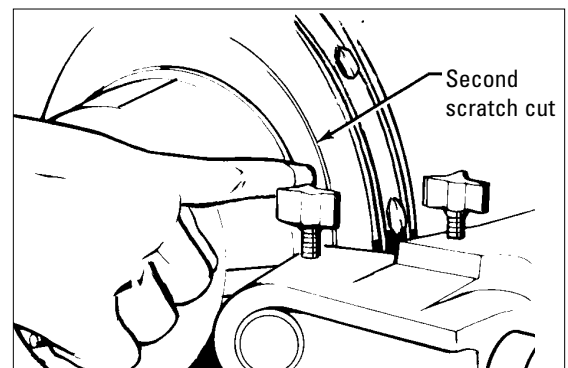

Figure 26 - Second scratch cut

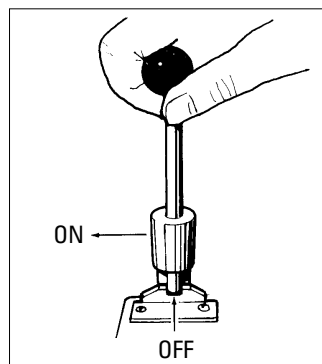

Figure 28 - Engage automatic cross feed

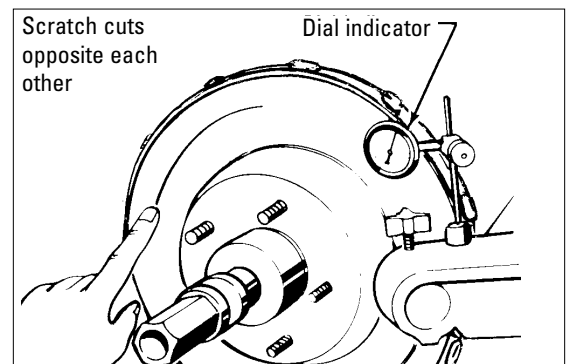

Figure 27 - Using a dial indicator

## Maintenance and Service

### Oiling

The lathe is shipped from the factory with the correct amount and type of oil. Check oil level frequently as shown in figure 29, and refill as necessary with EP-80-90 gear oil.

After every 500 hours of use, drain the oil and refill to the appropriate level on the dipstick with clean EP-80-90 gear oil. Use the oil drain plug on the front of the lathe to drain the old oil. See figure 30.

The drum feed gearbox and the disc brake feed mechanism assemblies are filled with a special lubricant and need no further internal lubrication.

Lubricate the cross feed once each month with automotive chassis grease. Pump the grease into the fitting until clean grease comes out the relief slot at the base of the fitting as shown in figure 31.

Use a hand pump grease gun only. A high-pressure gun can burst the lathe casting.

Grease the lead screw drive monthly (figure 32). Locate the lead screw drive by pulling the protective boot back.

Oil exposed metal parts periodically to prevent rust.

### Cleaning

Keep the lathe as clean as possible for trouble-free operation, as well as safety and longer lathe life. Use a brush to sweep metal chips and dust off the lathe.

Do not use compressed air to blow the lathe clean. Chips and dust may be driven between machined parts and into bearings, causing undue wear.

### Care of Arbors and Adapters

Although the adapters, arbors, and spindle are made of top grade steel and are turned, hardened, and precision ground to close tolerances, great care should be taken in their use, handling, and storage. Even the smallest nick, scratch, or loose chip can cause incorrect rotor or drum alignment, resulting in inaccurate reconditioning.

Remove all adapters from the arbor after reconditioning a drum or rotor and wipe them clean - especially the inboard adapter. When a finished drum or rotor is removed from the arbor, the inboard adapter may move slightly away from the face of the arbor and allow metal chips to fall into the opening, causing a poor mounting for the next drum or rotor.

Regularly inspect the faces and seating tapers of the adapters for nicks and scratches, correct any flaw with a fine stone. If the damage cannot be corrected, replace the adapter. Handle the adapters and arbors with care and store them on individual hooks. Do not throw them into a box. The adapters are designed for mounting drums and rotors only. Do not misuse the adapters.

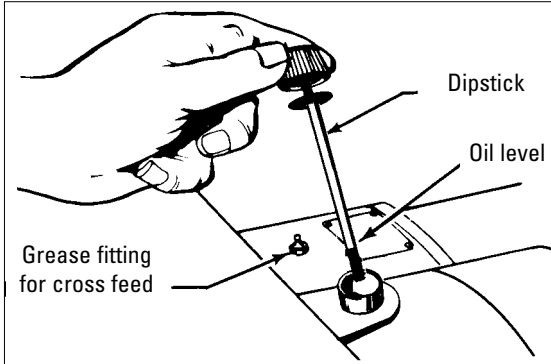

Figure 29 - Oiling

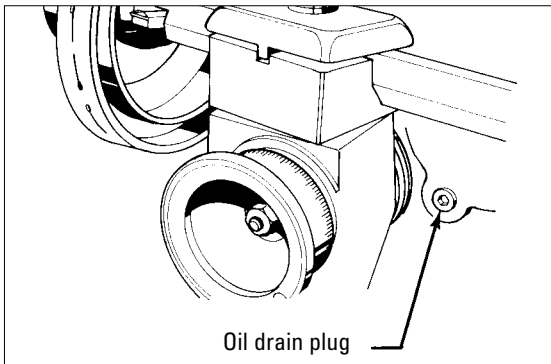

Figure 30 - Drain plug location

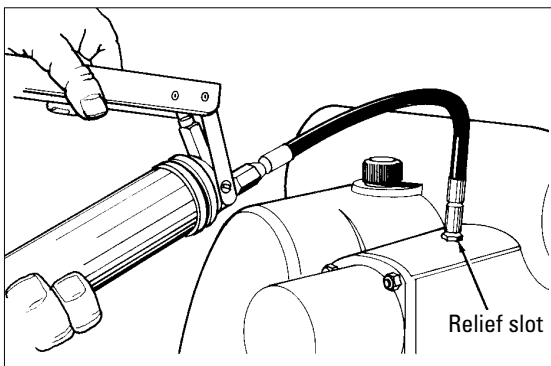

Figure 31 - Cross feed grease fitting

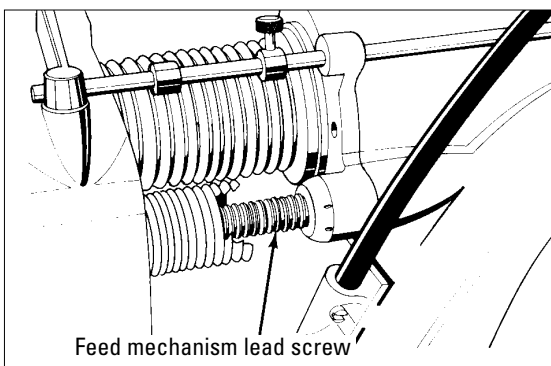

Figure 32 - Lead screw drive

## **Shear Gear Replacement**

The shear gear is located in the drive housing under the dot plug cover. It is designed to "strip out" and prevent gearbox damage should a tool accidentally jam.

Remove the dot plug button. Remove the C-clip. Remove the shear gear. Remove any stripped teeth from the drive housing. Install the new gear. The concave side of the C-clip faces the gear to maintain pressure. Replace the dot plug button.

## **Parts Identification**

The following pages illustrate and identify the component parts of the 4000 lathe. Complete parts breakdowns with exploded view illustrations are provided to facilitate the ordering of spare or replacement parts. Assemblies are outlined where it is recommended the individual parts not be ordered separately. These assemblies are furnished because some parts are staked, pinned, or press fitted, then drilled, machined, or bored. Accuracy must be maintained.

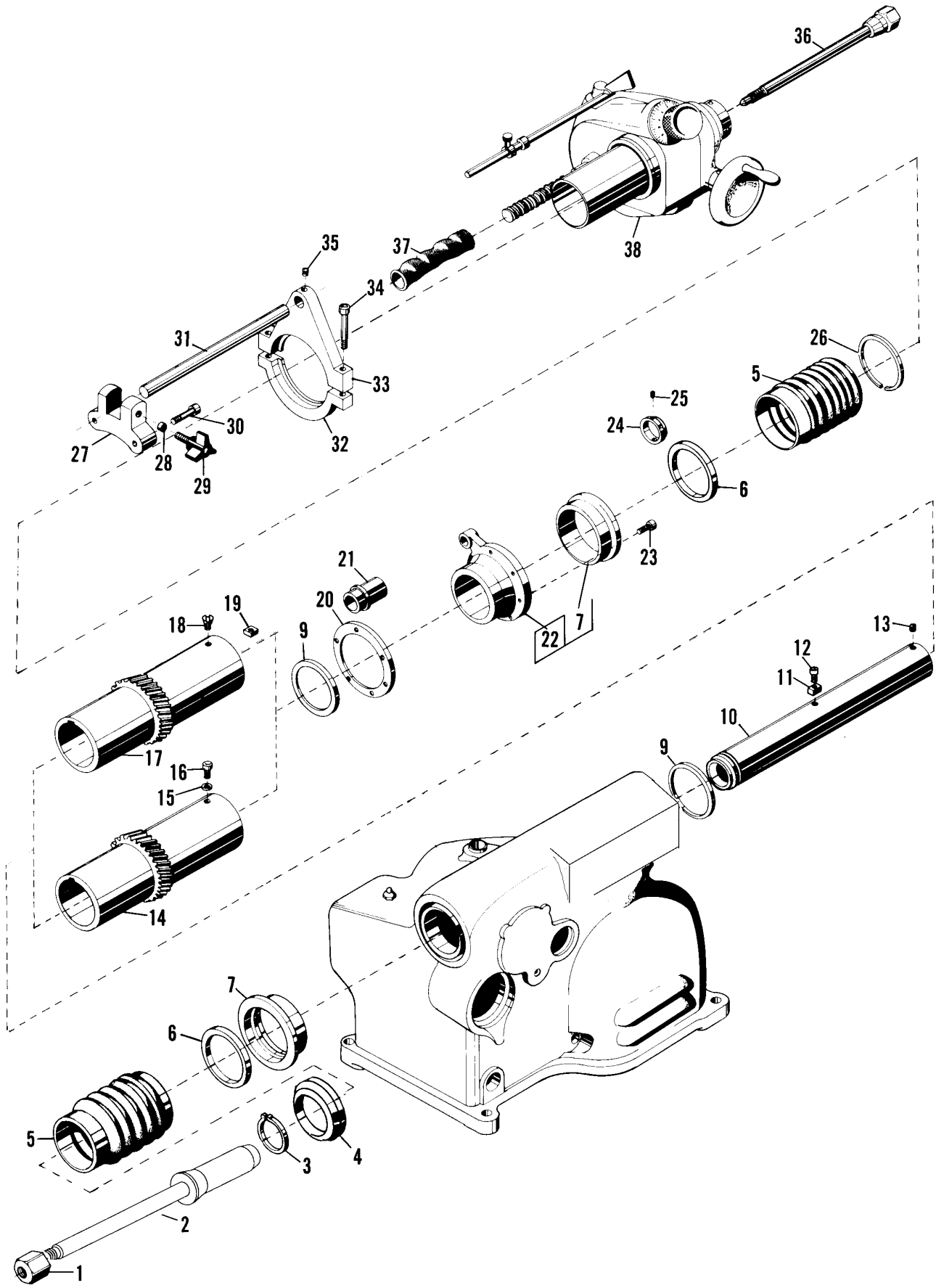

## Spindle

ITEM	PART NO.	Qty.	DESCRIPTION
1	3102	1	Nut, arbor
2	3101	1	Arbor
3	3159	1	Ring, retaining
4	23682	1	Ring, adapter
5	3085	2	Boot
6	40720	1	Seal, oil, double-lip
7	3089	2	Ring, oil seal adapter
8	3164	1	Seal, oil
9	3033	2	Washer, thrust
10	3153	1	Spindle body, 3000/4000
11	9831	1	Key, drive
12	6486	1	Screw, cup point set
14	9830	1	Quill, drive, 3000/4000
15	283	1	Washer, lock, 3000/4000
16	1602	1	Screw, hex hd. cap, 3000/4000
17	10216	1	Quill, drive, 4100/7700
18	6868	1	Screw, flat hd., 4100/7700
19	10737	1	Block, keyway, 4100/7700
20	903032	*	Shim (0.005 THK)
	921322	*	Shim (0.0075 THK)
21	4670	1	Nut, lead screw, 4000/7000
22	7344R	1	Rear flange assembly, 4000
23	209	4	Screw, skt. hd. cap, 4000, 4100
24	4671	1	Nut, take up
25	3338	1	Screw, skt. hd. set
26	4435	1	Ring, boot, 4000/4100
27	9592	1	Clamp, front
28	3142	1	Plug, brass
29	6854	1	Knob
30	3319	2	Screw, skt. hd. cap, 4000
31	9645	1	Rod, lock, 4000
32	9998	1	Clamp, rear, lower
33	9999	1	Clamp, rear, upper
34	6825	2	Screw, skt. hd. cap
35	213	1	Screw, set
36	7005	1	Drawbar & nut assy, 3000/4000
37	3086	1	Boot & spring, 3000/4000
38	3037	1	Feed mechanism, 4000

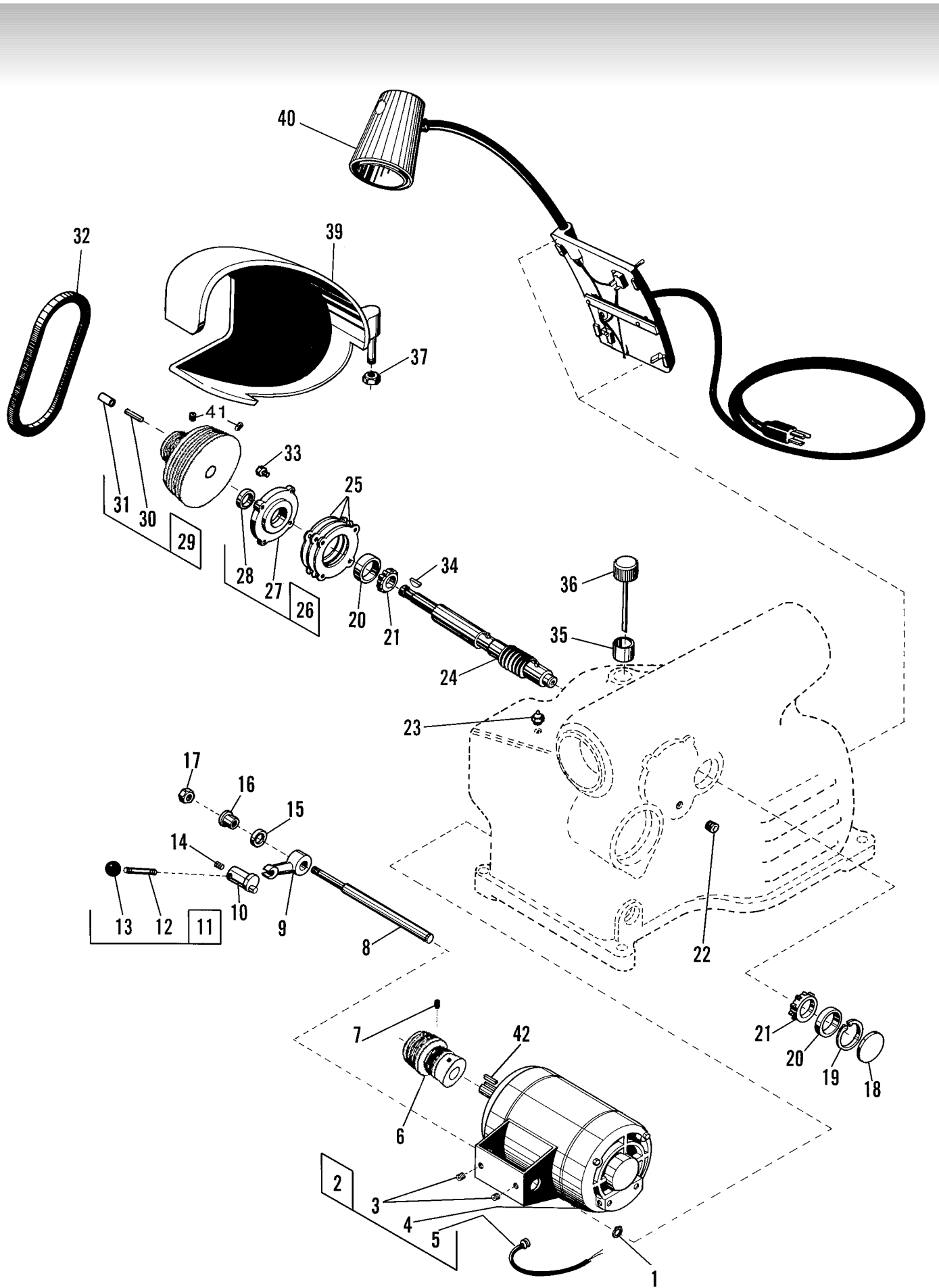

## Motor Mount and Drive Shaft

ITEM	PART NO.	Qty.	DESCRIPTION	ITEM	PART NO.	Qty.	DESCRIPTION
1	6766	1	O-ring	25	3169	*	Shim, 0.005" (*Quantity as required)
2	6101	2	Screw, hex hd. cap		3170	*	Shim, 0.007" (*Quantity as required)
3	21557	2	Washer, lock		3171	*	Shim, 0.020" (*Quantity as required)
4	2165	1	Motor/bracket assembly	26	3186	1	Cap and seal assembly
6	40538	1	Pulley, drive, 4000	27	3010	1	Cap, bearing seal
7	220	2	Set screw, 3000/4000	28	3163	1	Seal, oil
8	3023	1	Shaft, motor mount	29	40581	1	Pulley w/pin and tube, 4000
9	3015	1	Lever, belt tension	30	24239	1	Pin, groove, 4000/4100
10	3035	1	Pin, eccentric belt release	31	25588	1	Tube, rubber, 4000/4100
11	7348	1	Lever belt release assembly	32	40141	1	Poly V-belt
12	3088	1	Handle, belt release	33	236	1	Screw, hex hd. cap
13	320	1	Knob, ball	34	40139	1	Key, square
14	3180	1	Screw, socket hd.	35	3215	1	Sleeve, oil filler
15	2364	*	Washer, wave (* quantity as required)	36	3148	1	Dipstick
16	3223	1	Bushing, motor mount shaft	37	11273	1	Nut, self-locking
17	3377	1	Nut, hex	39	7788	1	Guard, belt
18	3166	1	Plug, Welch	40	10352	1	Panel assembly, electrical
19	3172	1	Ring, retaining I.D.	41	220	2	Screw, set
20	3394	2	Cup, bearing	42	25454	1	Key, square
21	3393	2	Bearing, Cone				
22	3372	1	Plug, allen pipe				
23	22006	1	Fitting, grease				
24	9847-C	1	Shaft, worm w/square key				

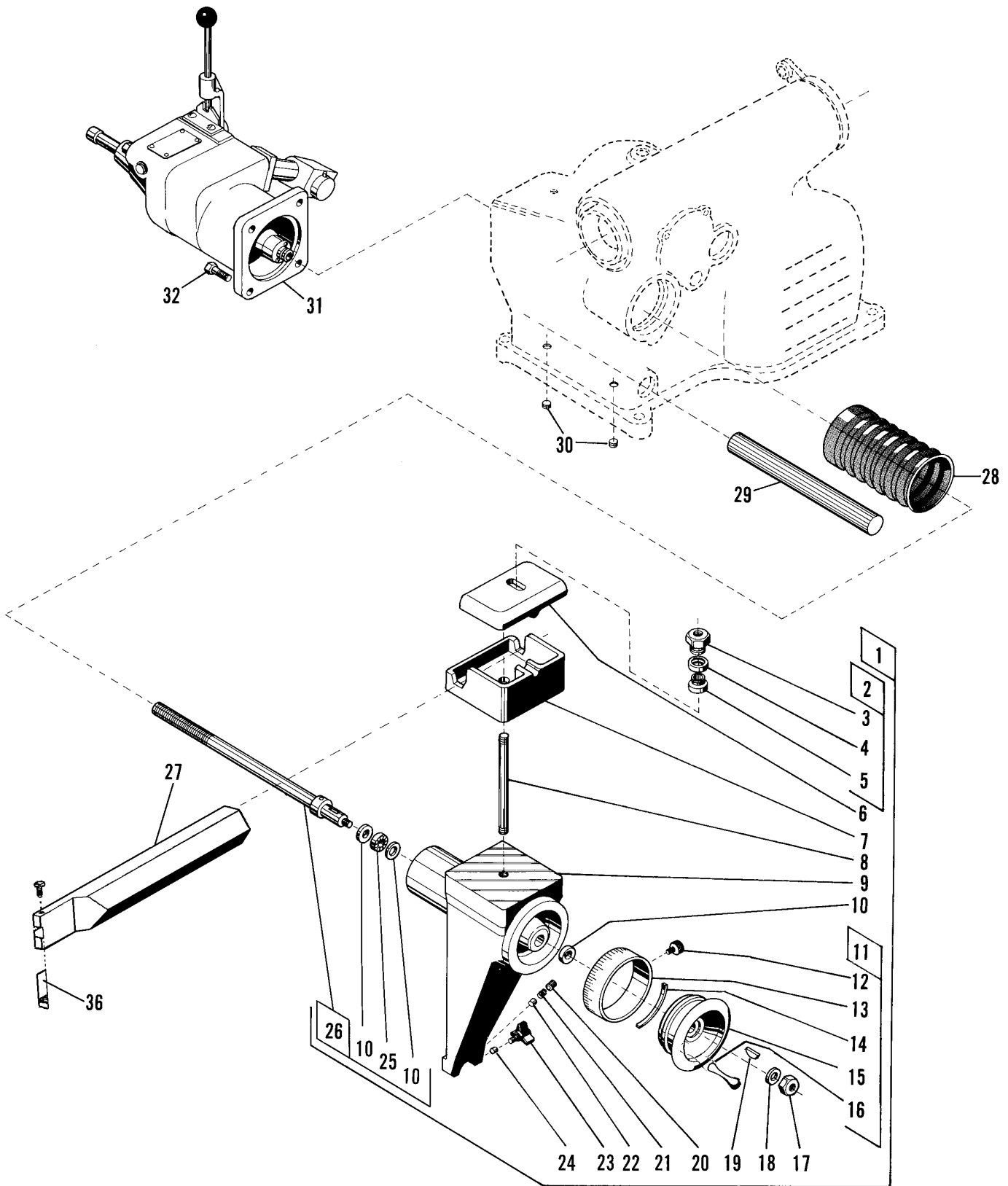

## Cross Feed Assembly

ITEM	PART NO.	Qty.	DESCRIPTION
1	7345	1	Cross feed assembly
2	11227	1	Nut/washer, hex, self-align, assy.
3	11221	1	Nut, locking
4	11225	1	Retainer
5	11224	1	Washer
6	3017	1	Clamp, boring bar, upper
7	20666	1	Clamp, boring bar, lower
8	3031	1	Stud, boring bar
9	9835	1	Cross feed
10	6874	3	Race
11	9626	1	Cross feed handwheel assy.
12	6839	1	Screw, set
13	9634	1	Dial
14	9611	1	Spring, dial
15	9633	1	Handwheel
16	3026	1	Crank, handwheel
17	2309	1	Nut, handwheel
18	3214	1	Washer, flat
19	3176	1	Key, woodruff
20	220	1	Screw, set
21	2064	1	Spring
22	9836	1	Plug
23	6854	1	Knob, locking
24	3142	1	Plug, brass
25	6873	1	Bearing, needle thrust
26	3211-1	1	Lead screw assy.
27	29240	1	Boring bar and screw assy.
28	3087	1	Boot and spring assy.
29	10346	1	Bar, guide
30	1680	2	Screw, hex hd. set
31	7751	1	Gearbox assy., 4000
32	237	4	Screw, cap, 4000/4100/7500
36	40558	1	Tool bit holder assembly, drum
	7681	1	Carbide insert, positive rake

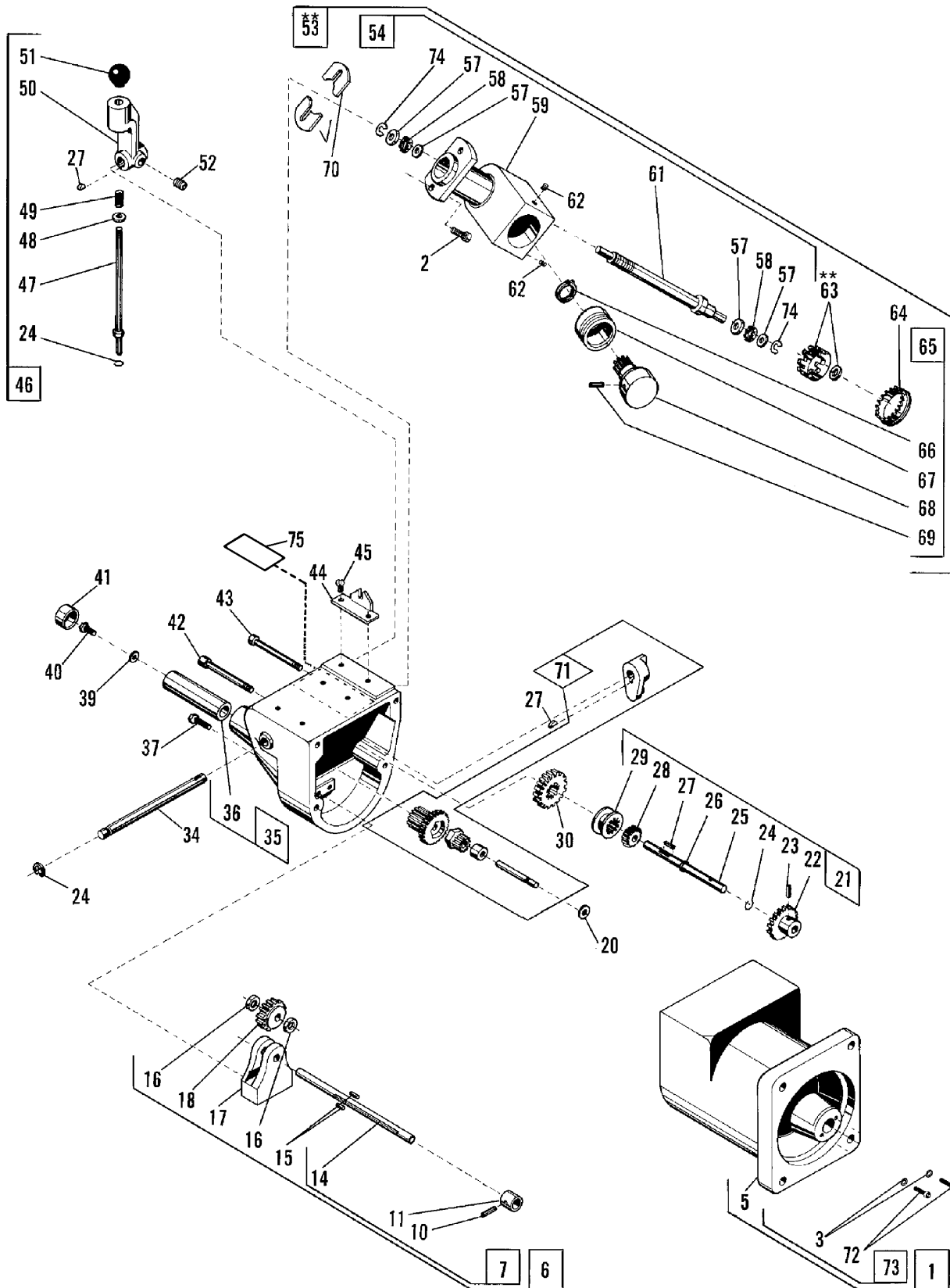

## Disc Brake Feed Mechanism, #7751

ITEM	PART NO.	Qty.	DESCRIPTION	ITEM	PART NO.	Qty.	DESCRIPTION
1	10870	1	Gear case assy.	54	24241	1	Worm drive assy.
2	3221	4	Screw, socket head	57	6872	4	Washer, travel
3	3910	2	Washer, lock	58	6871	2	Bearing, needle thrust
5	7790	1	Case, gear	59	7998	1	Housing and Bushing assy.
6	40718	1	Coupling assy.	61	7992	1	Worm drive assy.
7	40719	1	Universal coupling assy.	62	6834	2	Screw, cone point set
10	40403	1	Pin, roll	**63	7996	1	Shear gear and ring assy.
11	40717	1	Coupling	64	6446	1	Plug, dot
14	10340	1	Rod, drive	65	9821	1	Coupling assy.
15	6937	2	Pin, dowel	66	3174	1	Ring, retaining
16	6973	2	Washer, thrust	67	9825	1	Spacer and bushing assy.
17	7775	1	Trap	68	9822	1	Coupling and gear assy.
18	7778	1	Gear, drive	69	4096	1	Pin, roll
20	6350	1	Washer, bone shim	70	7908	2	Shim, 0.005"
21	9814	1	Shifter shaft assy.		7903	2	Shim, 0.010"
22	7994	1	Gear, helix		7904	2	Shim, 0.020"
23	4006	1	Pin, roll		7905	2	Shim, 0.030"
24	5613	2	Ring, retaining	71	24516	1	Shifter & intermediate gear assy.
25	7764	1	Shaft, clutch	72	28367	2	Screw, cap
26	6138	1	Ring, Retaining	73	28529	1	Lead screw nut kit
27	3176	5	Key, woodruff	74	5639	2	Ring, retaining
28	9816	1	Gear, fine feed	75	40529	1	Decal
29	9813	1	Clutch				
30	9812	1	Gear, coarse feed				
34	7748	1	Shaft, shift				
35	7902	1	Gear case cover and tube assy.				
36	7783	1	Tube				
37	3221	2	Screw, socket hd. cap				
39	4789	1	Washer				
40	6254	1	Screw, socket hd. cap				
41	6974	1	Cap, tube				
42	6392	2	Screw, hex hd. machine				
43	6391	2	Screw, hex hd. machine				
44	40521	1	Plate, index				
45	4508	2	Screw, round hd. machine				
46	7742	1	Shifter handle assy.				
47	7746	1	Pin, shifter handle				
48	6451	1	Washer				
49	7699	1	Spring				
50	7744	1	Body, shifter handle				
51	320	1	Knob, ball				
52	220	1	Screw, set				
**53	9815	1	Driven assembly.				



**\*\* The 940907 metal face gear can only be used in conjunction with lathes equipped with a circuit breaker located on the electrical panel.**

**The plastic 907996 shear gear must be used on lathes without the circuit breaker. Failure to follow these instructions may lead to minor personal injury or product or property damage.**

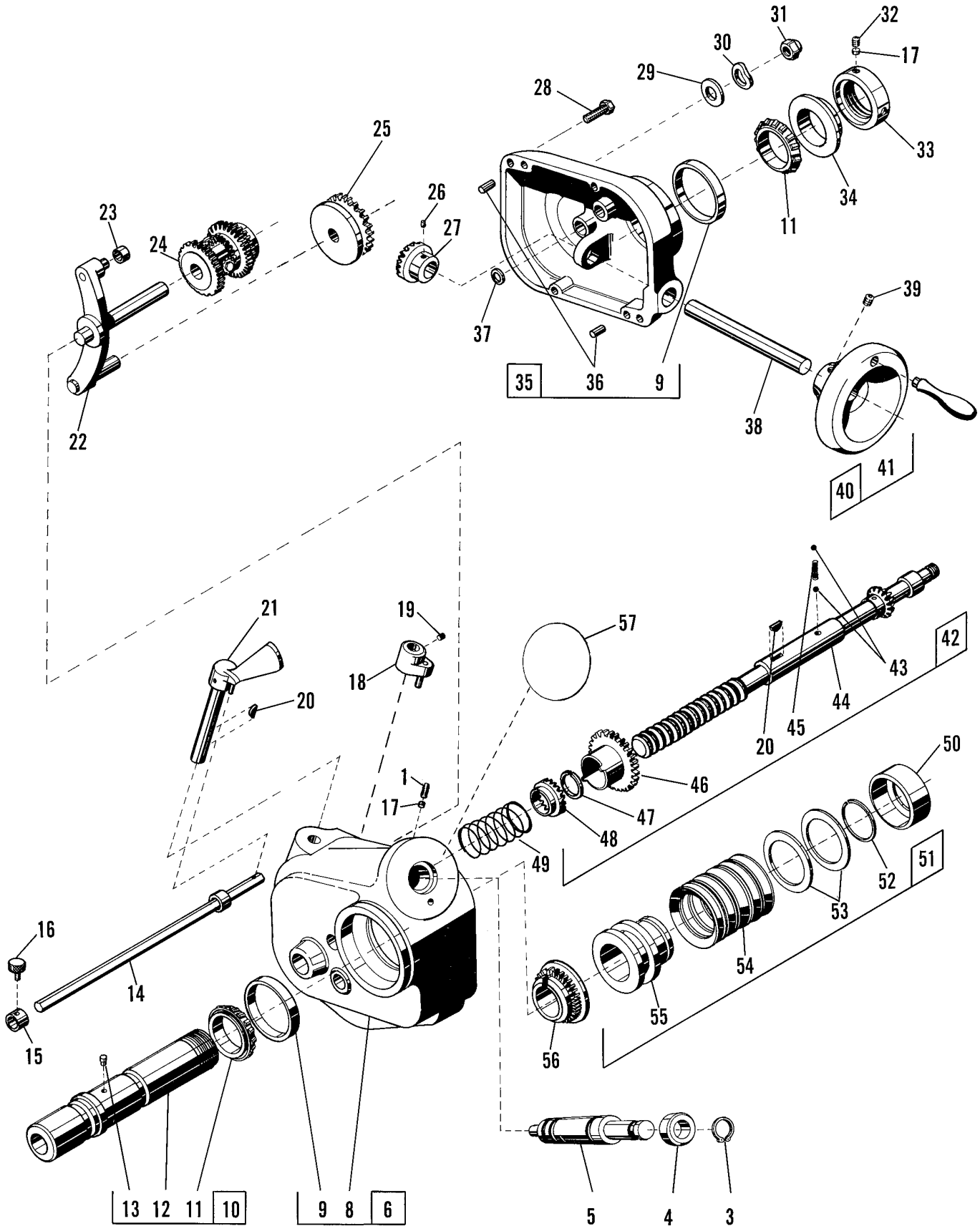

## Drum Feed Gearbox Assy. 3037

ITEM	PART NO.	Qty.	DESCRIPTION	ITEM	PART NO.	Qty.	DESCRIPTION
1	2308	1	Screw, allen set	45	3060	1	Spring, clutch
3	3097	1	Ring, retaining	46	3047	1	Gear, sliding clutch
4	9930	1	Bearing, thrust	47	6163	1	Ring, retaining
5	40533	1	Screw, feed adjusting	48	7264	1	Clutch jaw
6	3715	1	Gear case assy.	49	7263	1	Spring, coil
8	25182	1	Gear case	50	3061	1	Cup, spring loading
9	3392	1	Cup, bearing	51	3082	1	Friction disc assy.
10	7007	1	Spindle extension assy.	52	3093	1	Ring, retaining
11	3391	1	Bearing, taper roller	53	3064	2	Washer
12	3154	1	Spindle extension	54	3062	10	Spring, Belleville
13	3092	1	Pin, groove	55	3078	1	Disc, sliding friction
14	3040	1	Shut-off assy., 3000/4000	56	3077	1	Clutch, fixed friction
15	3039	1	Collar, stop	57	40530	1	Decal
16	3084	1	Screw, knurled	*Sold as assy. only			
17	3141	2	Plug, brass				
18	3058	1*	Clutch shifter assy.				
19	212	1	Screw, allen set				
20	4449	2	Key, Hy-Pro				
21	3042	1*	Clutch handle and shaft assy.				
22	7343	1*	Feed control lever and differential assy.				
23	3036	1	Roller				
24	7338	1	Pinion bushing assy.				
25	3081	1*	Driven friction disc & bearing assy.				
26	3098	1	Screw, dog point set				
27	3069	1	Gear, miter				
28	3094	4	Screw, socket hd. cap				
29	3324	4	Washer				
30	6155	1	Washer, wave				
31	3184	1	Nut, stop				
32	213	1	Screw, allen set				
33	9443	1	Nut, bearing lock				
34	9444	1	Washer, spherical				
35	9498	1	Gear case cover assy.				
36	3038	2	Pin, dowel				
37	4641	1	Washer, bone fiber				
38	3054	1	Shaft				
39	220	1	Screw, set				
40	3090	1*	Handwheel assy.				
41	3026	1	Handle, crank				
42	8235	1	Lead screw & clutch assy. 3000/4000				
43	311	2	Ball, steel				
44	9918	1*	Lead screw/miter gear assy. 3000/4000				

## 6950 Twin Cutter

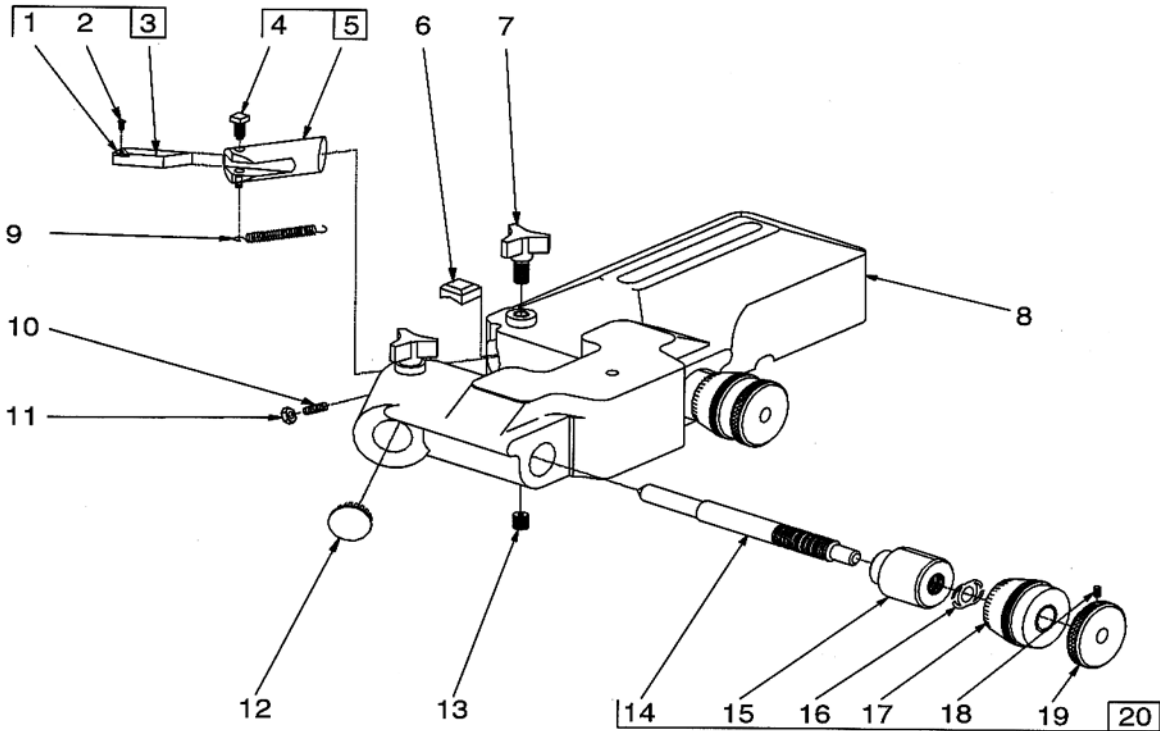

ITEM	PART NO.	Qty.	DESCRIPTION
1	7681	2	Carbide Insert, Positive Rake
2	6499	2	Screw, #4-40 x .25 Oval Head
3	40559	1	Holder, Tool Bit, Right Hand, Positive Rake
	40560	1	Holder, Tool Bit, Left Hand, Positive Rake
4	9249	2	Screw, Square Head Set
5	10650	1	Tool Holder, Left Hand
	10651	1	Tool Holder, Right Hand
6	28584	2	Gib, Brass, Tool Holder
7	6854	1	Screw, Lock
8	28572	1	Twin Cutter Housing
9	6905	1	Spring
10	9879	2	Screw, Locating
11	3528	2	Nut, Hex
12	6977	2	Plug, Dot
13	6109	2	Screw, 3/8-16 Set
14	6908	2	Rod, Dial
15	6906	2	Plug, Dial
16	6929	2	Washer, Spring
17	6907	2	Dial, Micrometer
18	3338	2	Screw, Set
19	6923	2	Knob, Dial Rod
20	6901	1	Dial Assy.

# Electrical Panel Assembly

110 V

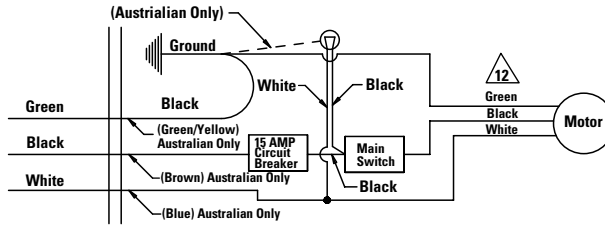

WIRING SCHEMATIC

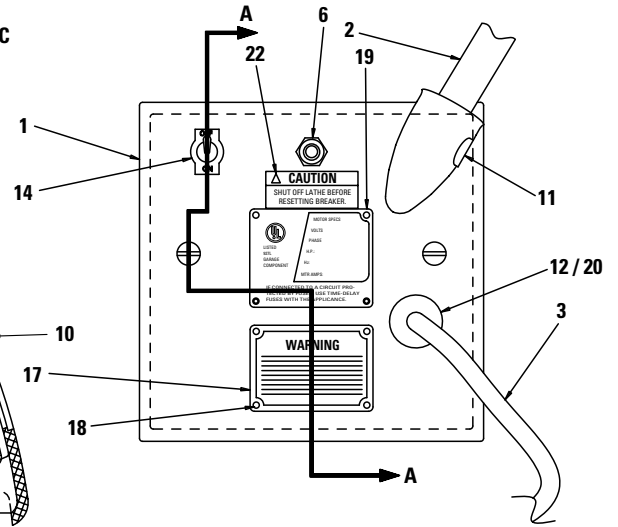
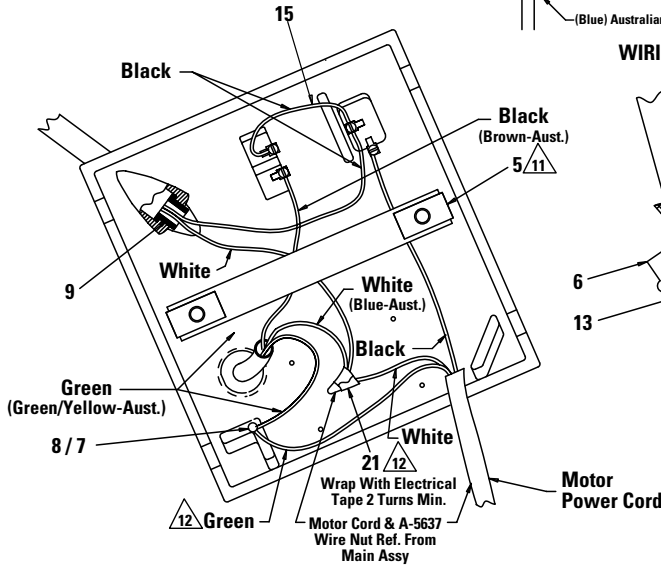

Item	Qty	Part No.	Description
1	1	910348	Electrical Panel
2	1	907963	Lamp Assembly
	1	929225	Lamp Assembly (Australian Only)
3	1	907209	Cord Set, 110 V
	1	907210	Cord Set, 220 V
	1	929507	Cord Set (Australian Only)
4	1	940388	Clamp Strap
5	2	940441	Tinnerman Nut
6	1	940868	15 AMP Circuit Breaker
7	1	921972	Self-Tapping, #6 Screw
8	1	901926	Lock Washer
9	1	906889	Bushing
10	2	903183	Round Head Machine Screw
11	1	900220	Set Screw
12	1	906058	Cord Grip, 110 V
	1	906077	Cord Grip, 220 V
	1	929643	Cord Grip, (Australian Only)
13	1	906893	Switch, 110 V
	1	921464	Switch, 220 V
14	1	901185	Switch Plate
15	1	940988	Black Wire Assembly
17	1	920463	Electrical Caution Tag
18	8	900306	Screw, Drive
20	1	929642	Knock-out Adapter
22	1	941103	Reset Decal

220 V

110 V

